

2 Wires

Company

For

Mechanical & Electrical Works

- **Company Profile**
- **Company Branches**
- **Duct Technology Factory Profiles**
- **Organization Chart**
- **Scope of Engineering Services**
- **List of Project**
- **References**

2 WIRES
Company Profile

Profile

2Wires Company established in 1997 is a reputable Egyptian Contracting Company based in Cairo. 2Wires Company has a great outstanding contracting experience; it is specialized in Air Conditioning, Electrical Works, Testing & Commissioning of all Electro-Mechanical machines & Equipments, Safety & Fire Fighting, HVAC Systems & Technical Installations.

2Wires Company has developed immensely throughout the years and has increased its resources. 2Wires has established a Duct Technology Factory for manufacturing of sheet metal, HVAC, duct works & supplying accessories. Thus, providing a very superior quality of products and services to meet all the customers' requirements. The Company's improvement is due to its team of professional and competent engineers, who offer high quality designs, supervision and execution of first class quality finishing, renovation works with a large scope of electro-mechanical projects.

2Wires Company selects its individuals who are exceptionally qualified, professional, reliable and efficient who not only excel in their fields, but who are passionate about their work. Their passion drives them to accomplish work at an outstanding level in contracting, installing and servicing in order to meet the complete satisfaction of our clients.

Eng. Ossama Adib

Chairman

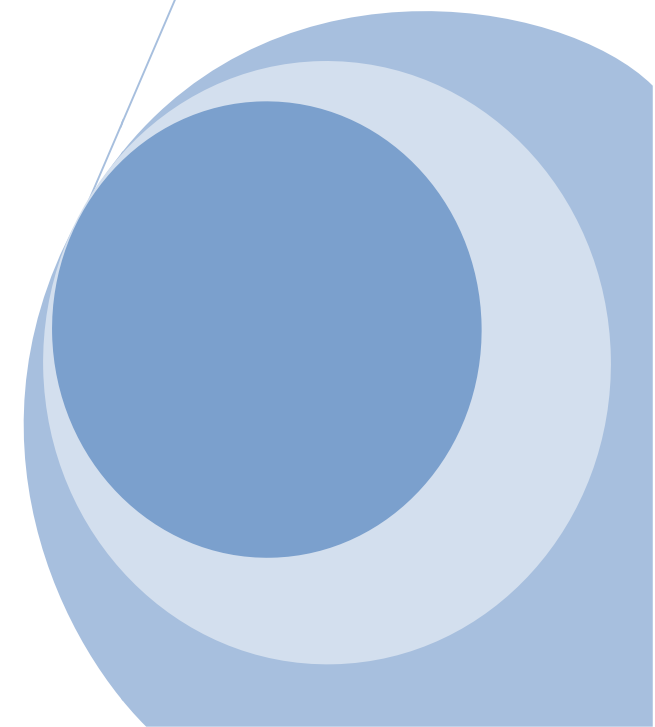
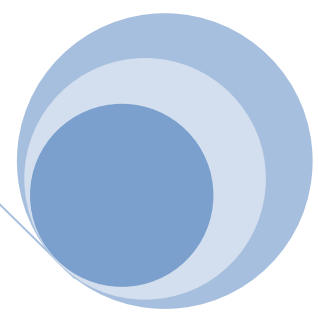
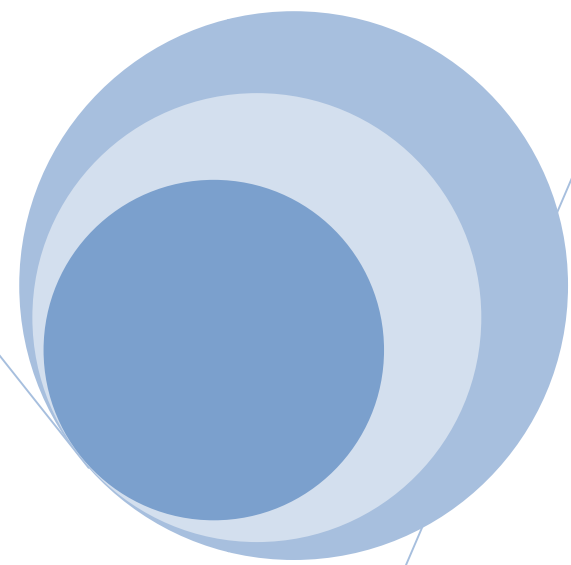

COMPANY PROFILE

Contact Us at:

Office:

55 EL Montazah Street (in front of El Fath Mosque) Heliopolis, Cairo, Egypt

Website: www.two-wires.com

E-mail: twowires@two-wires.com

Tel: (202) 26363549 – 26334784 – 26334808 –26336500 – 26339066

Fax: (202) 26338990

Mob: 0106654062

CONTENTS

- **Company Profile**
- **Organization Chart**
- **List of Projects**

• Company Profile •

2 Wires – TESTING & BALANCING SERVICES DEPARTMENT is specialized in testing, adjusting, and balancing of heating, ventilating, air-moving equipment, air-conditioning systems and hydraulic systems.

The Company's improvement is due to its team of professional and competent engineers, who offer high quality designs, supervision and execution of first class quality finishing, renovation works with a large scope of e testing projects.

Also we have the latest versions of the testing and balancing instruments which give us the ability to complete our works perfectly

We follow the instructions and procedures of the associated air balance (AABC) to:

- Ensure that proper methods and procedures are followed in the test and balance process
- Provide a better understanding of the scope of work required
- Work with design professionals to achieve design intent

2 Wires selects its individuals who are exceptionally qualified, professional, reliable and efficient who not only excel in their fields, but who are passionate about their work. Their passion drives them to accomplish work at an outstanding level in order to meet the complete satisfaction of our clients.

Eng. Ossama Adib
Chairman

• Organization Chart •

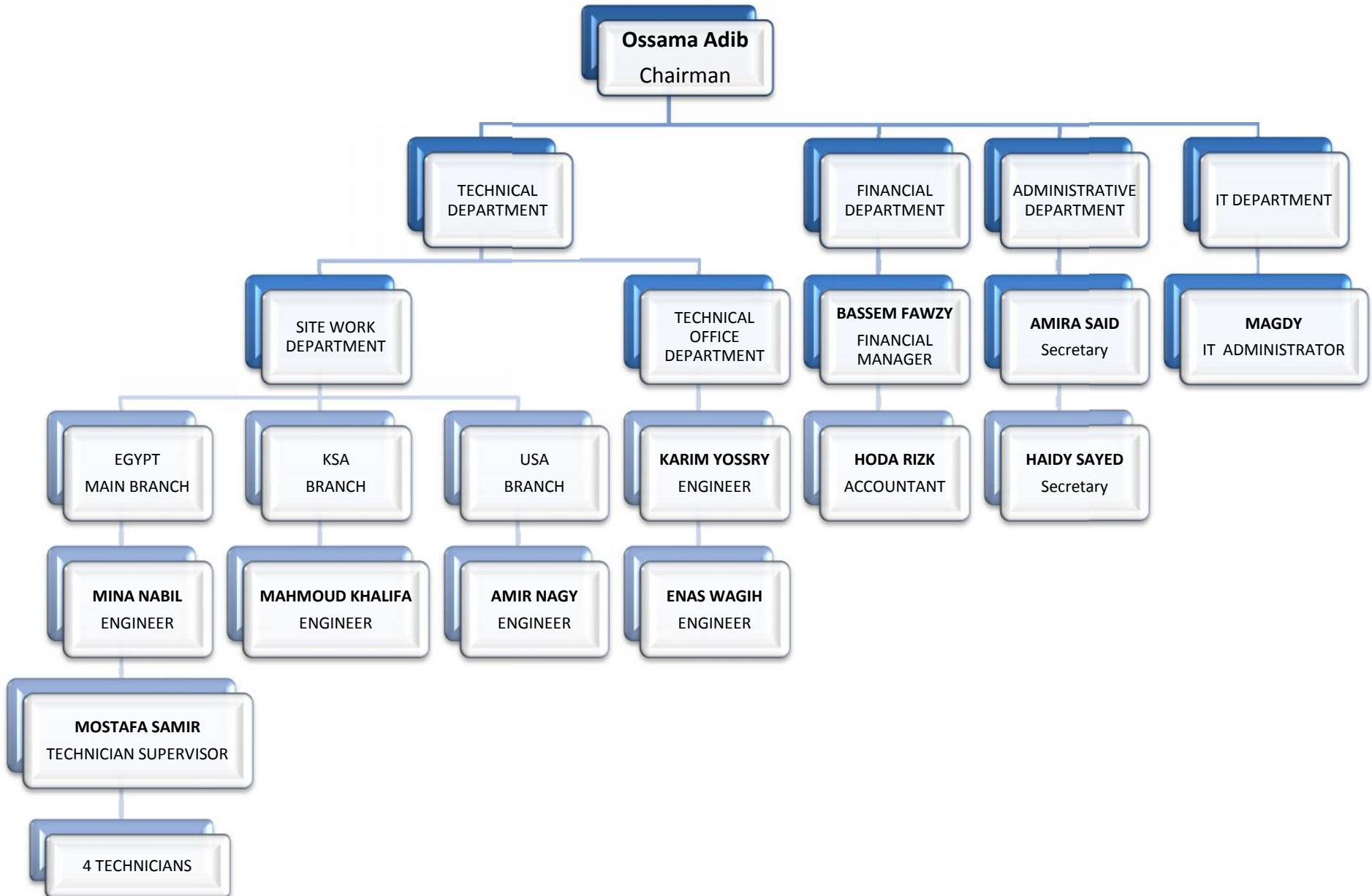

• List of Projects •

- **EPPC PDH & PP COMOLEX Factory - Port Said, Egypt.**
- **SHOURA COUNCIL - Cairo Downtown, Egypt.**
- **Mubarak Police Academy - New Cairo, Egypt.**
- **Al- Koraymat Power Station – 000, Egypt.**
- **27 EL Harby Factory - Belbis road, Egypt.**
- **Harmony Resort - Makadi Bay, Sharm El-Sheikh, Egypt.**
- **Luxor Air Port – Luxor, Egypt.**
- **Metito Co. Head office - Hazem Hassan, Giza, Egypt.**
- **Motorola - Nile City, Cairo, Egypt.**
- **Vodafone Head Quarter - 6th October, Egypt.**
- **Luxor Air Port – Luxor, Egypt.**

- **Barclays - City Stars, Cairo, Egypt.**
- **Barclays - Alex, Egypt.**
- **Barclays - 6th October, Egypt.**
- **CIB - Giza, Egypt.**
- **CIB - Thawra, Egypt.**
- **NSGB - Ismailya, Egypt.**
- **NSGB - Agooza, Giza, Egypt.**

AHC Co.
Advanced HVAC Consultant
Engineers & Contractors

5A Maroutya St., Haram-Giza- Cairo, Egypt.
6th Floor (Apartment No.: B)

TEL NO.: 00202- 7447036 / 7601614
TEL NO.: 002010-1501790

REF NO: 2W-11/2010

DATE : October 30, 2010
TIME : 11:58 AM

TO : Whom it may Concern

FAX NO : -

ATTN. : -

FROM : Eng. Hany Srour

CC :

TOTAL : 1 (Including this page)

**RE: TESTING AND COMMISSIONING REF PROJECTS FOR
2 WIRES Co.**

Dear Sir,

With ref. to the above-mentioned subject we would like to declare as an HVAC consultant that "2 wires" had been involved in some of our projects and have done a very professional, respective work in the expected period of time for the testing and commissioning of the HVAC systems.

This has been achieved during the last 7 years in the following projects.

No.	Project Name
1	Main conference hall - New cairo
2	Health Club – 6 th October
3	CIB Giza Branch –Giza
4	Sonesta Hotel-Cairo
5	Governmental administration Bldg – Alex
6	Entertainment bldg - New Opera- Cairo

This certificate was given to 2 wires upon their request with no legal obligation on AHC consultant.

Sincerely Yours
Mechanical Section Head

Hany srour

Hany srour



To whom it may concern

Uhde GmbH, a member of the ThyssenKrupp group of companies, is contracted by EPPC to construct an PDH/PP Complex Factory in Port Said, Egypt.

During the period of commissioning work of the HVAC systems Two Wires has successfully completed the Air flow Measurements of the different HVAC systems.

The work showed the application of technical and quality standards. Two Wires proved to be experienced, co-operative and capable to emit the assigned responsibilities.

Our joint work and meetings are impressed by a fruitful and successful co-operation atmosphere on an high technical level standard.

Due to the quality of Air flow Measurements we highly recommend them.

This certificate has been issued upon Two Wires's request with no responsibility to our company.

9.7.2010 
Dr. Frank Seidemann
Lead Engineer HVAC



Branches

Contact Us At:

Head Office in Egypt :

55 EL Montazah Street (in front of EL Fath Mosque) Heliopolis, Cairo, Egypt
Tel: (202) 26363549 – 26334784 – 26334808 – 26339066 – 26336500 – 0106654062
Fax: (202) 26338990
Mob: 0106654062
E- mail: twowires@two-wires.com

Main Branch Office

85 EL Montazah Street, Heliopolis, Cairo, Egypt
Tel: 26356332--26356328-- 26328176
E- mail: twowires@two-wires.com

Kingdom of Saudi Arabia Branch

OLYA North Tower MEKKA ROAD - Khobar office no. 103
Tel. +966 3 8328843
Fax. +966 3 8323045
Mob. +966(0) 552313269
E- mail: info@saasco.co.sa

USA Branch

Add: 11890 Sunrise Valley Drive, Suite 207, Reston, Va 20191, USA
Tel: 571-230-6270
Email: info@two-wires.com

Visit Us At:

Website: www.two-wires.com

Workshops:

A total of 2 workshops in Cairo located in "El-Herafeyin City", totaling 700 square meter encompassing Relevant machines and equipments, such as Welding machines, Metal saw machines, Metal bending Machines, Steel metal cutting machines, Pick-up trucks, Polishing machines, Grinding machines, Specialized Drilling machines and Compressors.
Tel: (+202) 26984949

Warehouses:

A total of 4 warehouses around Cairo City and vicinity, located " down town, El-Mokattam, El-Maadi And El-Herafeyin".
Tel: (+202) 26995693 – 26995694 – 26995695
Fax: (+202) 26994388
The balanced geographical distributions of 2 WIRES' facilities enable us to provide service for a wide Variety of customers.

Show Room:

Maadi Nerko
Tel: (+202) 25216418



Duct Technology



**THE LEADER IN EGYPT FOR SHEET METAL
MANUFACTURE AND ACCESSORIES**

DUCT TECHNOLOGY Factory is specialized in manufacturing of sheet metal for HVAC duct Works and suppliers for accessories.

We are Suppliers for the largest companies in the world:

(1) Duro Dyne Co. (the greatest name in sheet metal necessities in (USA).



(2) Lead' Air International Co. (the leader in Europe for sheet metal supplies and accessories).



(3) PAL International Co. for (pre-insulated foam ducting).



We established a factory for duct technology and imported a PRO-FABRICATE DUCT machine (U.S.A made) for making HVAC ducts according to standard and specification of SMACNA; these ducts are with different kind of special joints profiles such as:

- 1: TDC transverse joint (flanged).
- 2: Slip and drive transverse joint.
- 3: Slip on flange joint.

As standard SMACNA Duct Joint.

We have also imported a new version of PLASMA CUTTING machine (U.S.A.made) with the latest technology first time in Egypt, to do shapes and models to complete all the requirements for duct lines.

DUCT TECHNOLOGY Factory is unique in speed, quality and advanced technology as the work is run through 24hrs a day producing 20 tons of sheet metal duct lines varied by (thickness, dimensions).

This enlargement of our production line was due to comply with the increased demand and to fulfill our customers' requirements; having proved ourselves in the local market due to our outstanding performance, professional and efficient personnel and engineers.

Chair man
Eng.ossama adib

EMPLOYEES:

DUCT TECHNOLOGY is a team of professional and competent Engineers and foreman, who offer high quality Products with advanced finishing and services.

The staff includes:

- 5 specialized B.Sc. Engineers who were highly trained under specialized Americans consultants.
- 6 full time foreman.
- 40 steel and duct fixers.
- 2 Accountants.
- 2 Sales men.
- 4 Store keepers.
- 10 Workers.

The staff consists of honest, qualified and professional individuals, managed by an equally reliable and efficient administration.

Sister Company:

2 Wires Company for Electromechanical works and Duct technology Factory are working under Management of One chairman Eng.ossama adib.

Main office and show room:

36 said Ghareeb division, El Salam city, Cairo
Mobile: 0100081495- 0100081042-0107771980.
Tel.:+202 26971069
Fax. +202 29671070
Email:info@ducttechnology.COM
Web. Site: WWW.ducttechnology.COM

Duct Technology provides three techniques for manufacturing ducts according to SMACNA.....

1. Slip & Drive transverse joint

Duct length: 1.22m

Recommended for the small sizes of ducts from 0- 18 inch.

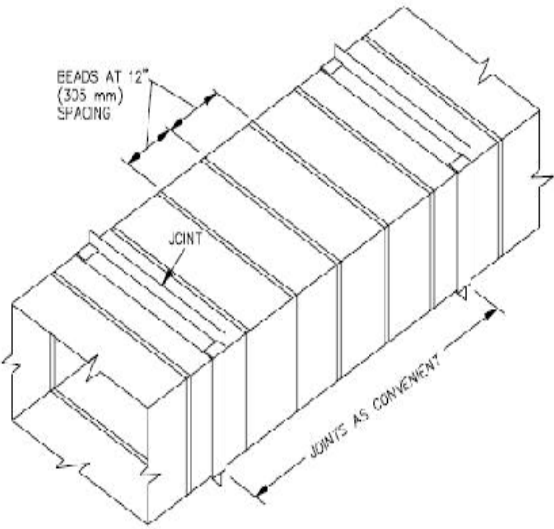
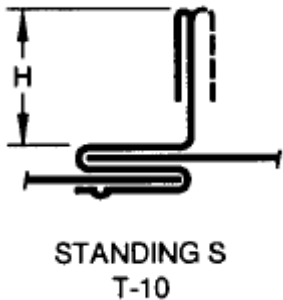
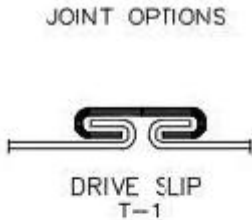

2. Slip on flange technique

In this technique ducts formed and we install flanges on it, we supply American (duro dyne) profile A35 and Belgian (lead'air) profiles according to following table

Duct length: 1.25m

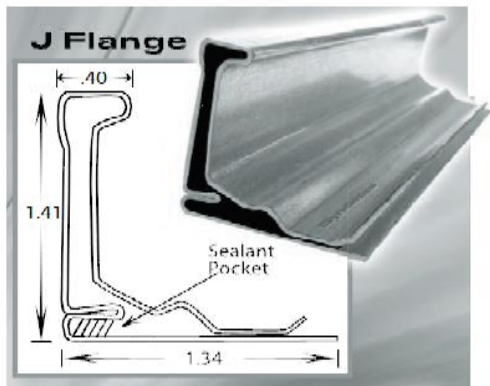

profile	Low pressure		medium pressure		high pressure	
	A max	A+B max	A max	A+B max	A max	A+B max
E20-A20	1450	2500	1250	2000	1000	1500
E30-A30	2250	3750	2000	3000	1500	2500
A40	4000	6000	3000	5000	2500	400
Clamps	X= max 600mm		X= max 500mm		X= max 400mm	

Belgian (lead'air) profiles

In this technique Rectangular duct must be assembled according to these instructions:

○ BEFORE ASSEMBLY

The ducts must be free from dirt.

○ Assembly instructions:

- Only use undamaged rectangular duct and fittings.
- Apply continuous gasket to effectively seal flanges and corners.
- Fasten the duct and fitting together with bolts & nuts at four corners.
- Mating flange shall be locked together by duct clamps.

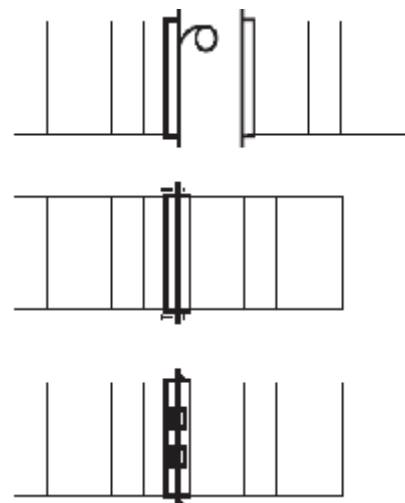

- The following numbers of duct clamps are recommended:

duct dimension mm	number
0 - 200	0
250 - 400	1
450 - 600	2
650 - 800	3
850 - 1000	4
1050 - 1200	5
1250 - 1400	6
1450 - 1600	7
1650 - 1800	8
1850 - 2000	9
2050 - 2200	10



3. Flanged (T.D.C) technique

In this technique flanges formed from ducts and we install corners and clamps

Duct length: 1.15m

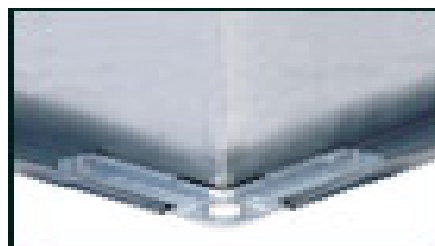

**FLANGED
(WITH GASKET)
T-25a**



1. Straight ducts

All straight ducts are beaded at equal spacing (305mm) according to SMACNA

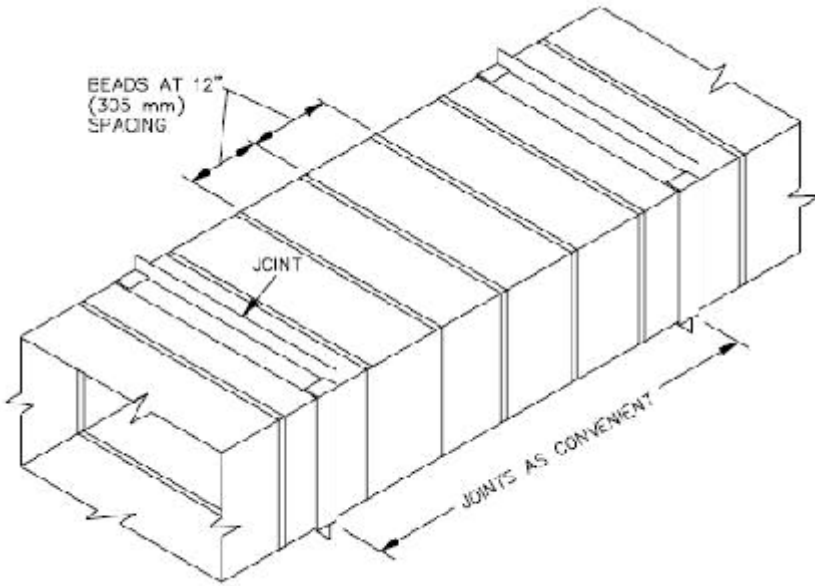

Longitudinal Seam

Pittsburg lock

This type consists of male side (9mm) & female side (35mm)

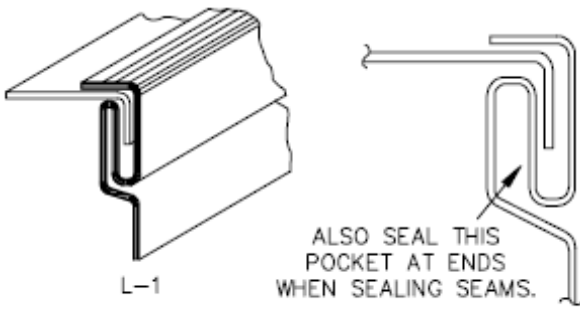

PITTSBURGH LOCK

SEAM LOCATIONS

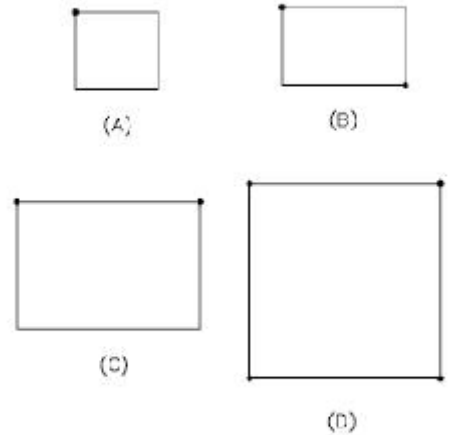

NUMBER OF SEAMS AND LOCATION VARIES WITH JOINT TYPE, SHEET ROCK AND ASSEMBLY PLANS.

* Seam numbers and locations vary according to joint type and size.

Ordering

Duct W x H x L

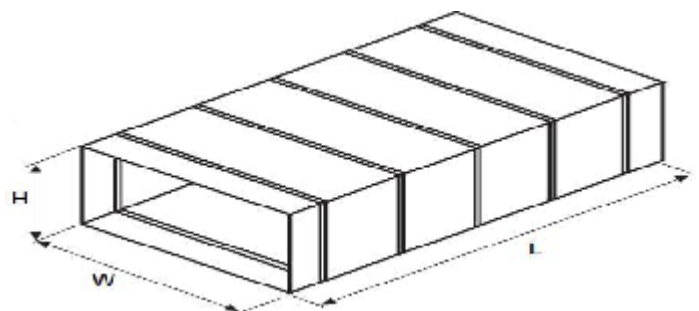

2. Reducer

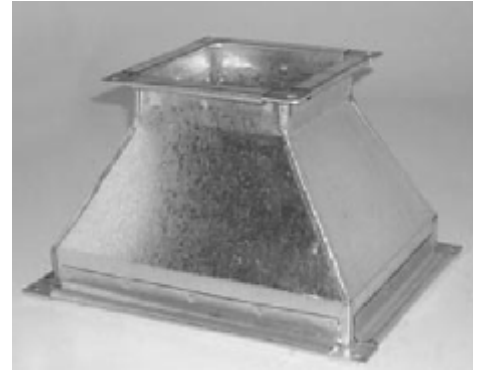
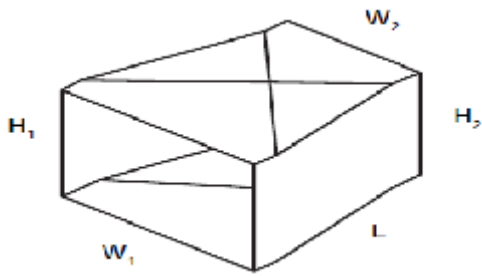

Order reducer $W_1 \times H_1 / W_2 \times H_2$ with length L

3. Radius Bend

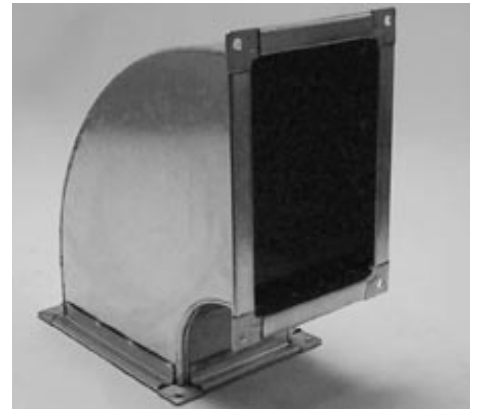
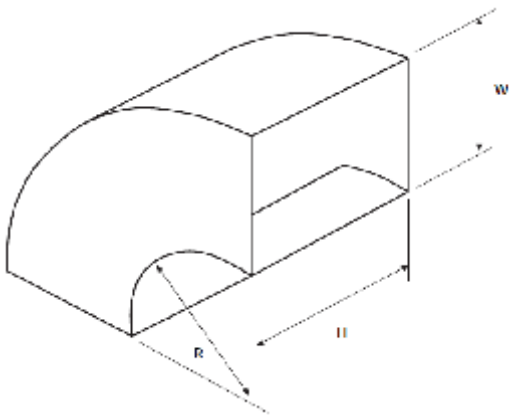

Ordering Radius bend $W \times H$ with radius or throat R

4. Tee

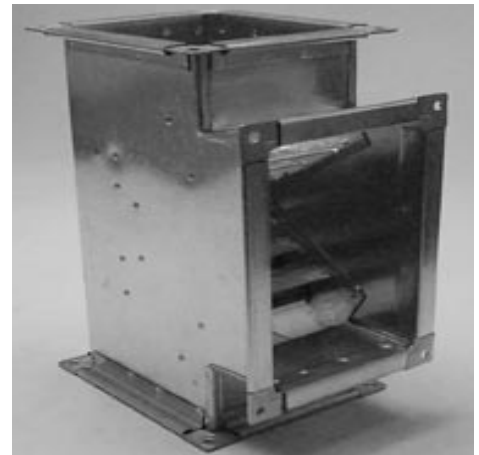
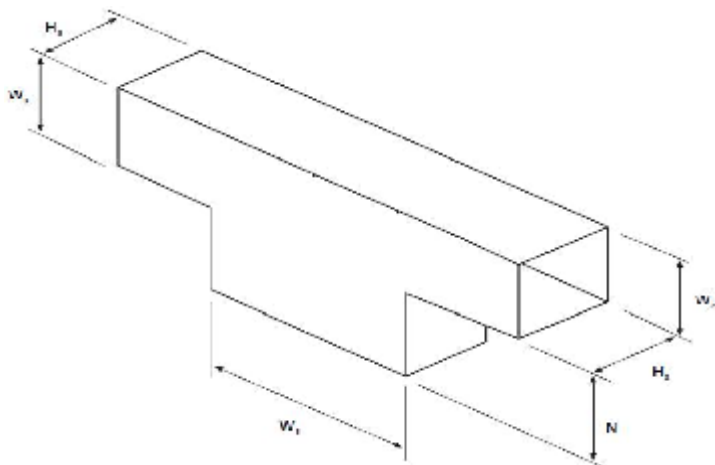

Ordering Tee $(W_2 \times H_2) (W_3 \times H_3) / (W_1 \times H_1)$ with throat N

5. Offset (S shape)

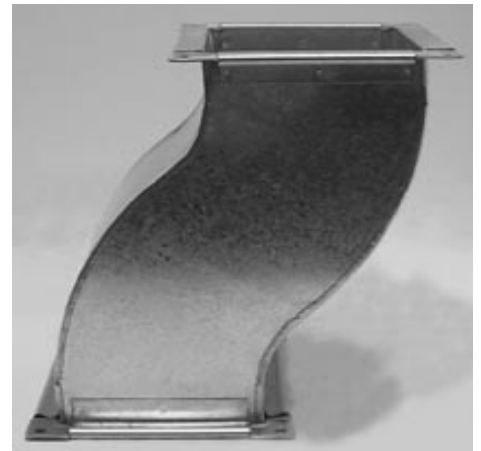
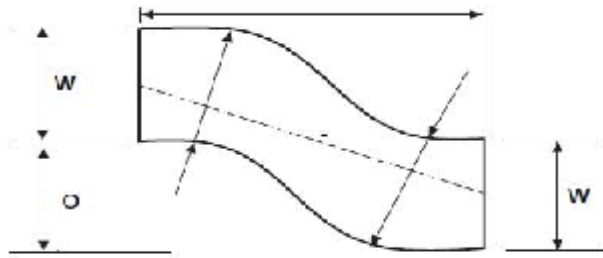

Ordering Off W x H x O x L

6. R-fitting or parallel flow branch

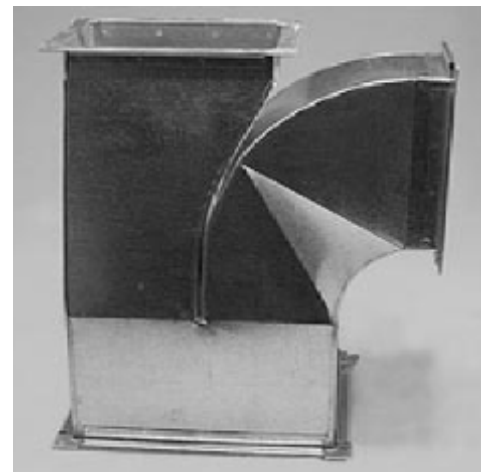
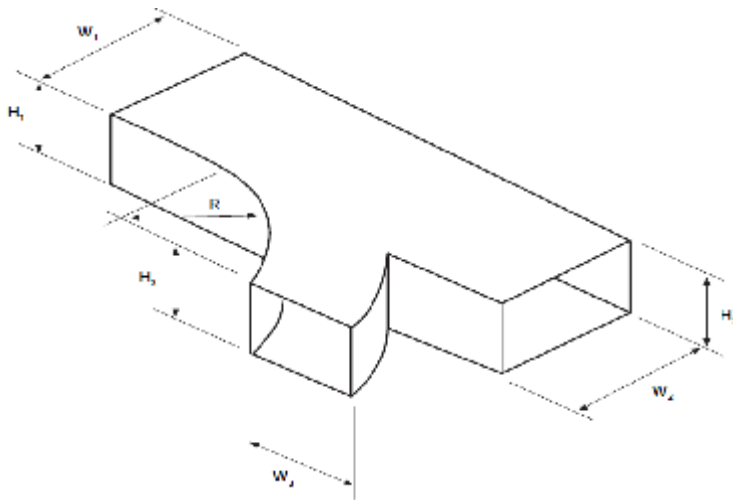

Ordering RF (W2 x H2) (W3 x H3) / (W1 x H1) with radius R

7. Split bend

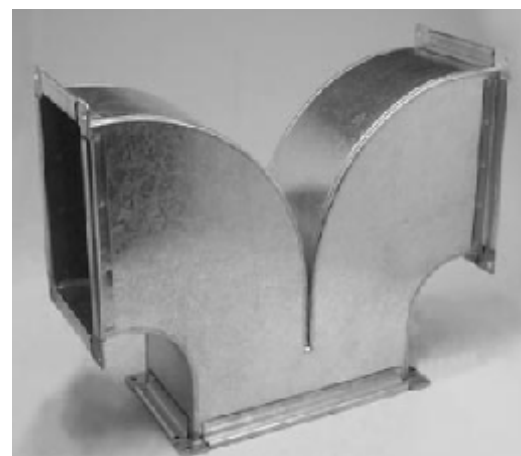
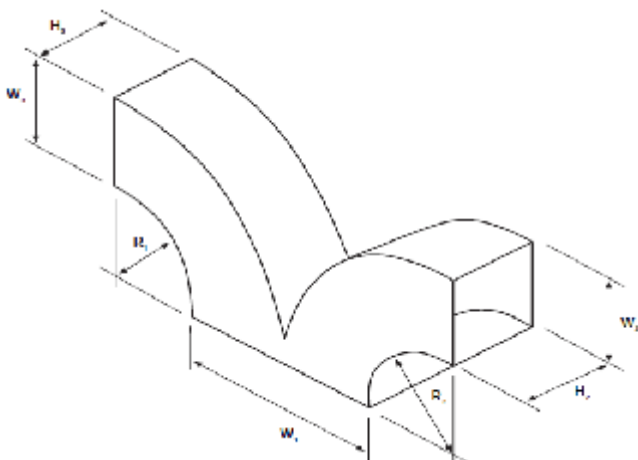

Ordering SB (W2 x H2) (W3 x H3) / (W1 x H1) with radius R1 and R2

8. Transition, rectangular to round.

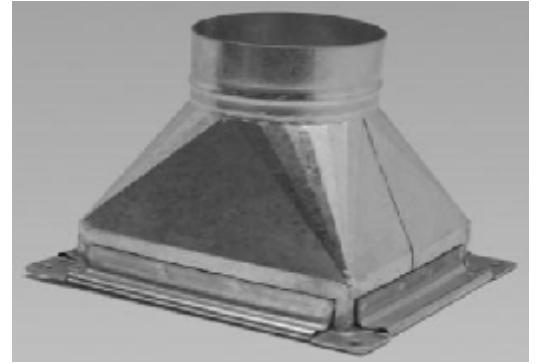
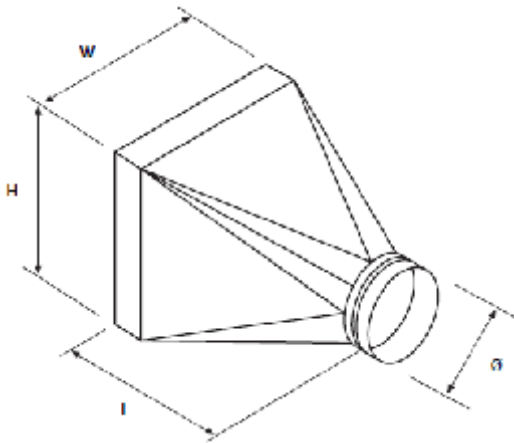

Ordering Trans (W x H) / Ø with length L

9. Take off 45°

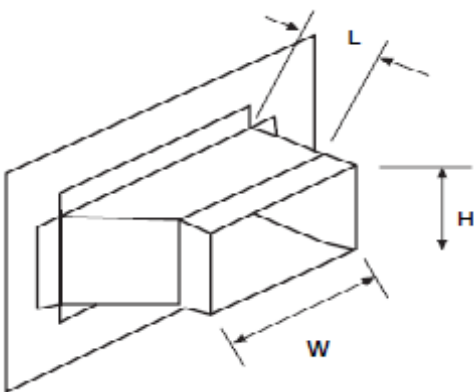

Ordering TO 45° (W x H) with length L

10. Take off 90°

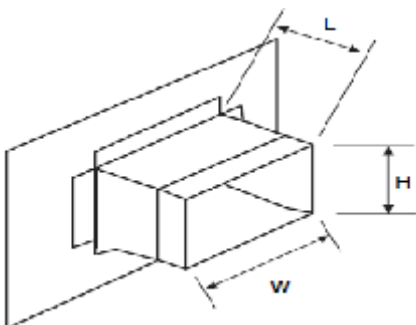

Ordering TO 90° (W x H) with length L

11. Round Branch connection /take off

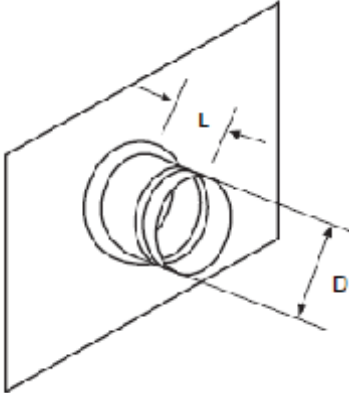

Ordering RB (D) with length L

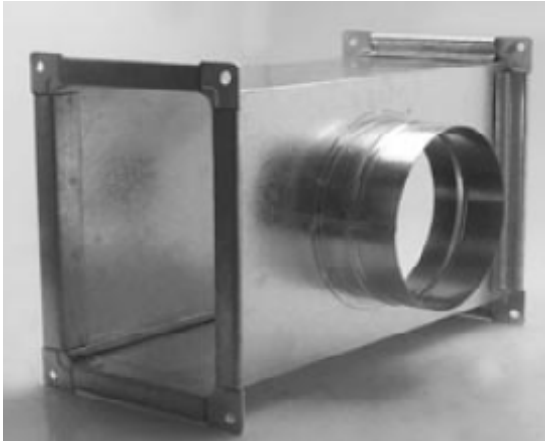

Machines and equipments

Duct technology is unique in Egypt with its machines with high technology in manufacturing ducts.

Pro fabricate duct machine

Produced by **Iowa Precision Industries (U.S.A.)**, the leader in custom designed and manufactured automated coil processing systems, has the experience and proven know-how to develop systems meeting the specific goals of customers, worldwide.



- Produces commercial and residential ducting
- Modular design with 11 integrated flexible workstations
- Notches vees and corners
- Forms Pittsburgh, TDC, slip & drive seams and joints
- Automated production control with integrated PC
- Operator programmable. The controller will store up to 100 programs for easy recall
- Modem included for remote factory support
- Processes flat sheets, 4-piece duct, "L" duct sections, "U" duct sections and wrap around duct sections



L-Duct sections with TDC flanges and Pittsburgh seam

Plasma cutting machine (Vulcan® 1000D)

Produced by Lock former (U.S.A.) The leader in the production of roll forming equipment.

For more than 65 years, Lock former® has led the world in the production of roll forming equipment. While the heating, ventilation and air conditioning (HVAC) industry is the company's primary market, Lock former® continues to expand into new areas.



LOCKFORMER

The Vulcan 1000D
Plasma Cutting System

Vulcan software makes you work more productive whether you have five or fifty people in your shop. Fitting input is quick, simple, and non-repetitive. Create customized, color-coded labels and reports easily.

Comprehensive Fitting Libraries: Choose from our comprehensive library of fittings from residential to the largest industrial applications.

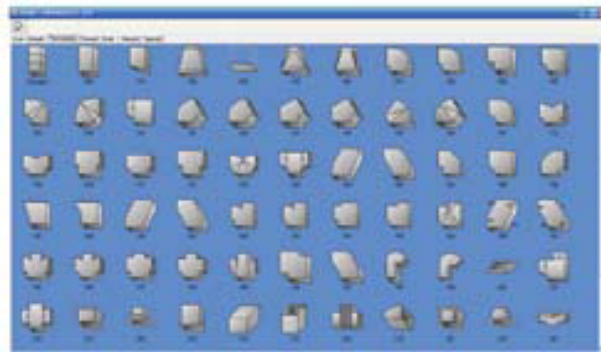

Automatic Shape Nesting: Reduce scrap levels significantly with automatic shape nesting. Go from blanking out each fitting to blanking out an entire job.

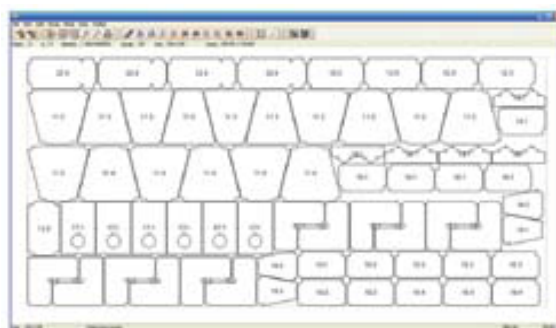

Accessories Division

Duct technology is agent for the two largest companies in the world:

- (1) **Duro Dyne Co.** (the greatest name in sheet metal necessities in (USA).
- (2) **Lead' Air International Co.** (the leader in Europe for sheet metal supplies and accessories).



Flange & Cleats From DURO DYNE

DYN-O-MATE FLANGES

DOMJ Flange

- Designed to strengthen the duct wall and connect duct sections together.
- Furnished with an integrated sealant pocket for a secure air tight fit.
- Manufactured from 20-gauge steel in 12ft. length.
- DOMJ is designed for large commercial and high-pressure applications.

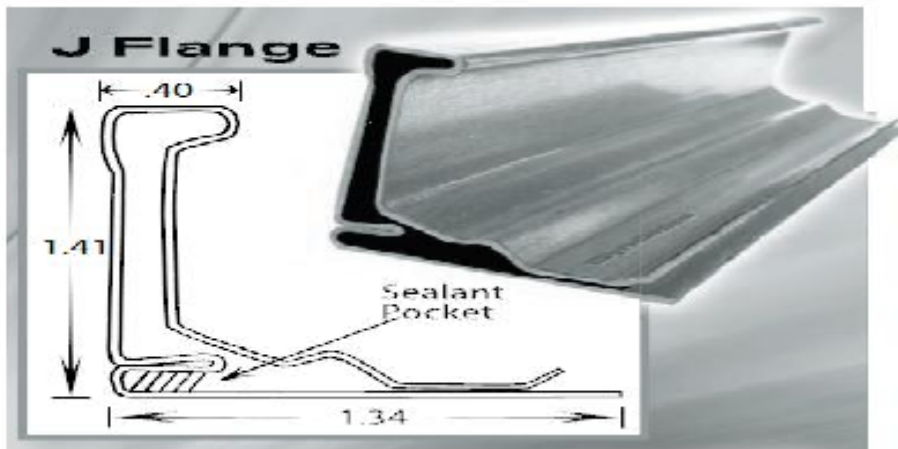

DYN-O-MATE CLEATS

- DOM-CLT and TDF-CLT are manufactured from 20 gauge galvanized steel 6" pieces.
- TDC/TDF-2230 is 22 gauge steel formed into lengths of 30" long and divided into five 6" cleats that are partially cut through allowing them to be easily separated into 6" pieces.

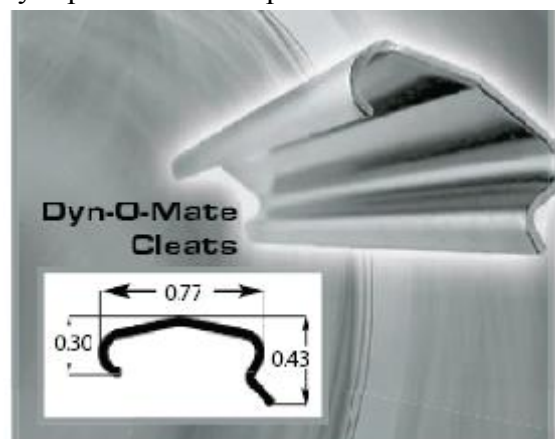
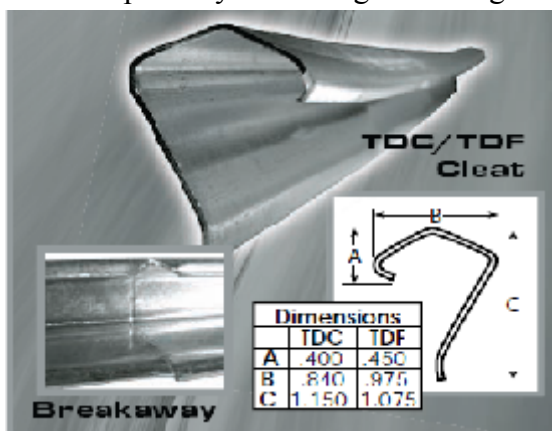

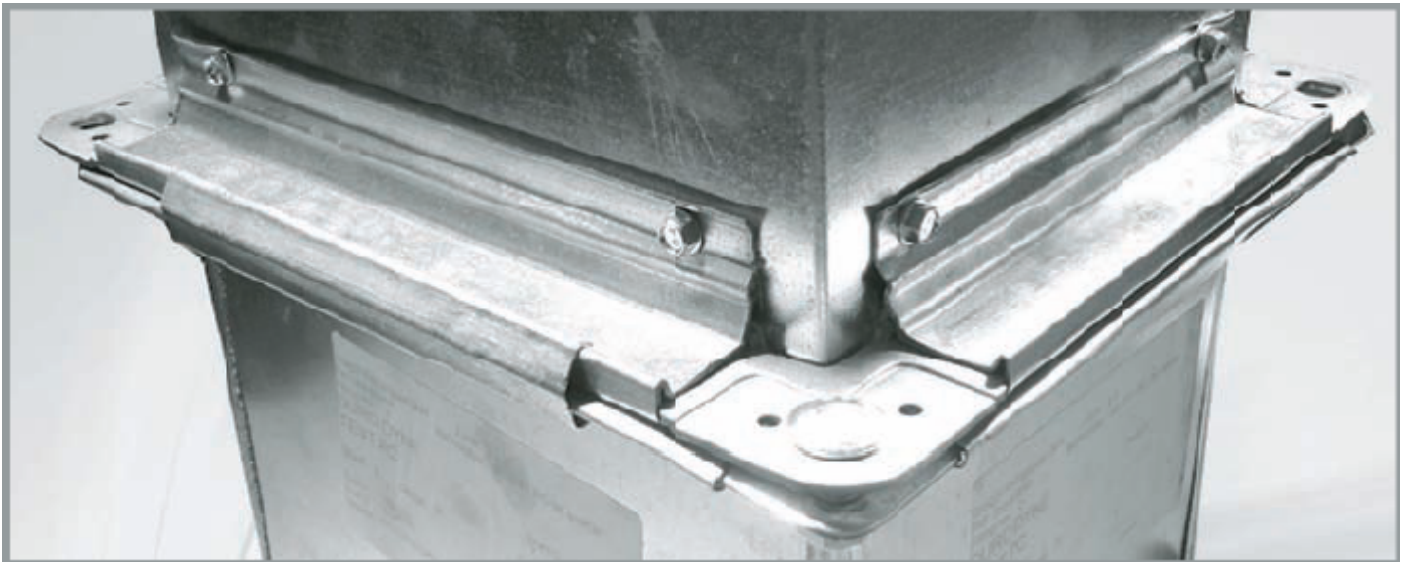

Corners

- DDJ corners are manufactured from 11-gauge steel for use with DOMJ Flange.
- DOMC corners are manufactured from 16-gauge steel.
- DDCS (TDC) corners are for use in corner insertion machines and are manufactured from 16-gauge steel.

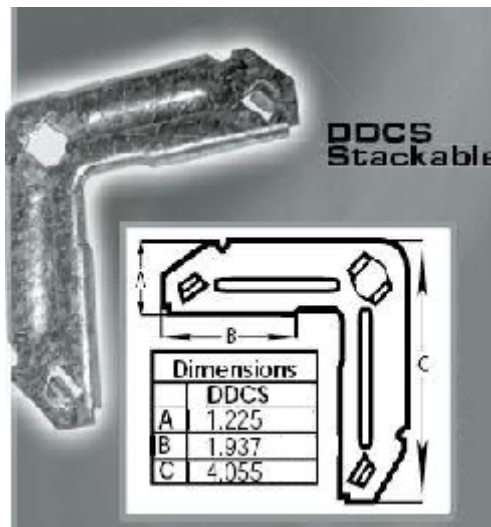
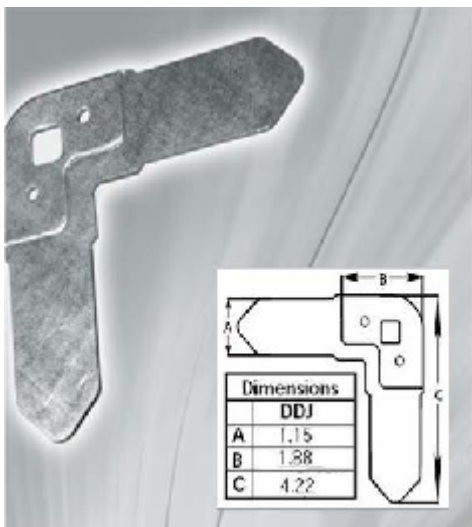
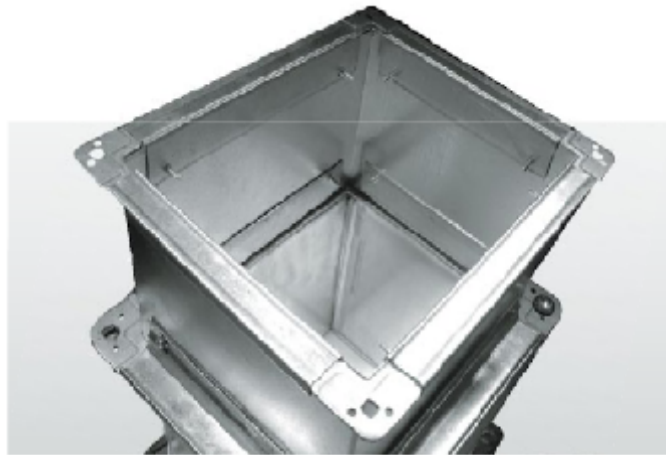

DYNA-TITE SYSTEM BENEFITS from DURO DYNE.

- Its time saving qualities have been shown to reduce installation by up to 6 times compared to traditional threaded rod.
- It provides a fast and strong solution to the task of hanging Mechanical and HVAC Systems.
- It allows the installer to position the hangers vertically or at an angle to the suspended object.
- Dyna-Tite System is lightweight and easy to carry, and combines these qualities with the inherent strength of high tensile wire rope.
- Its light weight improves safety on the job. Carrying the product on the job site is easy and, in aerial situations reduces accident risk caused by falling materials.

DYNA-TITE CABLE LOCKS

APPLICATIONS

Dyna-lite cable locks and wire rope can be used for suspension in a variety of ways to accommodate most mechanical & HVAC construction applications.

UNIT HANGING

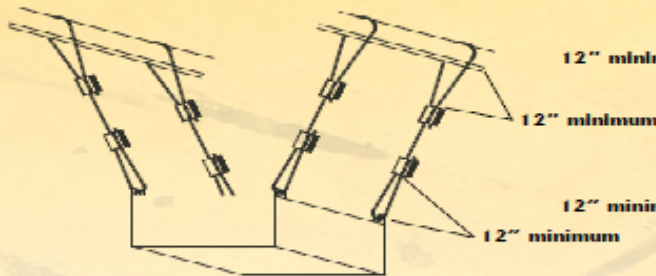

RECTANGULAR DUCT WORK

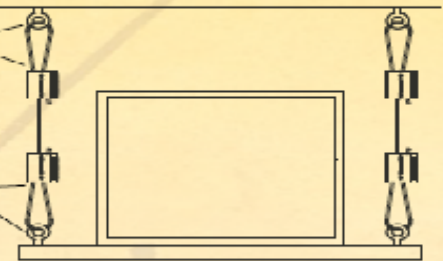

SPIRAL DUCT WORK

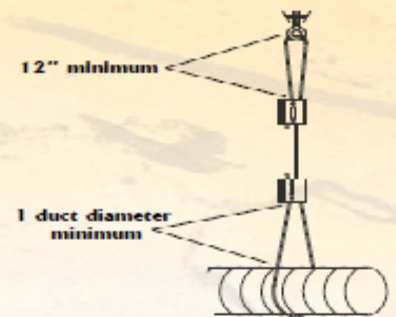
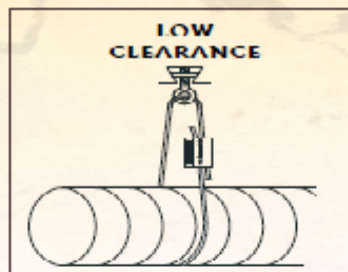
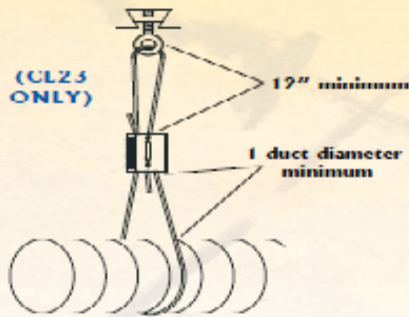

CL23 Cable Lock

- The Maximum Load Range for each size wire rope incorporates a design safety factor of 5:1. The CL23 and wire rope combination should be sized for the job so that the projected load falls within the appropriate working load limit (WLL).
- Wire Rope for use with CL23 is supplied in rolls. The 1/8 inch comes in 500 foot rolls. The 3/16 inch wire rope is supplied in 250 foot rolls. (1/8 inch wire in 250 foot rolls and 3/16 inch wire in 125 foot rolls is available on special order.)

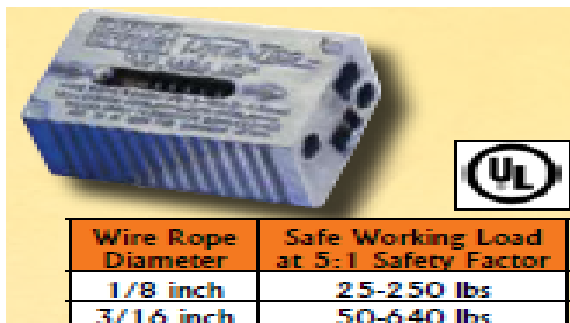

CL12 Cable Lock

- The CL12 is designed for use with either 1/16 inch or 3/32 inch wire rope. The wire rope is available in 500 foot rolls. As with all Dyna-Tite cable locks, the CL12 includes release pins for easy adjustment. The CL12 is the perfect product for hanging smaller diameter spiral (less than 24 inches), typical residential and light commercial ductwork, and air handlers in attics.

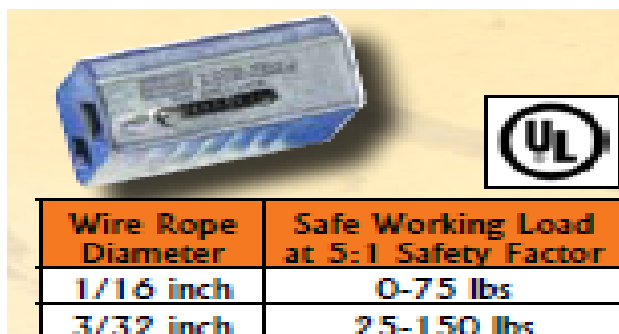

Cut-away section showing the Cable Lock internal components

ZINC HOUSING

Zinc alloy combines major anti-corrosion properties with strength while providing consistent manufacturing quality.

SERRATED TEETH

Each pawl makes contact with the rope using serrated teeth. These press onto the wire rope and spread the load across the length of the pawl, maximizing the grip strength.

WIRE ROPE ENTRY

The wire rope is inserted into the Dyna-Tite channel.

STAINLESS STEEL SPRINGS

The springs, one in each channel, are manufactured of stainless steel.

LOCKING PAWLS

One sintered steel locking pawl is seated in each channel. Every locking pawl incorporates a release pin for easy adjustment after installation.

THROUGH HOLE (only on CL23)

Two "through holes" allow fast and secure hanging with only one Cable Lock.

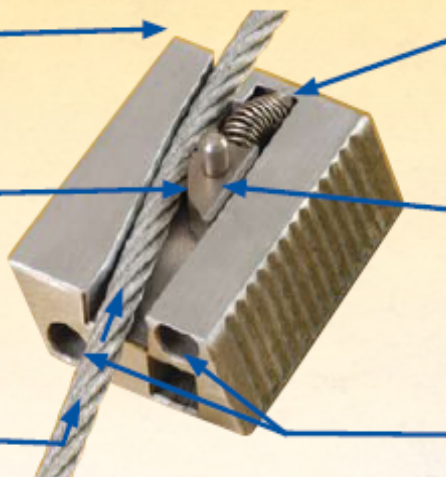

Flexible duct connector from DURO DUNE:

INSULFLEX			
ITEM	DESCRIPTION	SPECIFICATIONS (Metric)	FEATURES
#10173 IDC 343 INSULFLEX	Color: Black Base Fabric: Polyester Coating: Vinyl Insulation: Fiber Glass	Fabric Weight: 9 oz./sq. yd. (305 g/sq. meter) Tensile Strength: 70 lbs. x 70 lbs. (311 N x 311 N) Tear Strength: 8 lbs. x 11 lbs. (36 N x 49 N) Low Temp: 40°F (-40°C) High Temp (Continuous): 180°F (82°C) Galvanized Steel Thickness: 28 gauge (.47 mm) Insulation Thickness: 1" (25.4 mm) Density: 1.34 lbs./cu. ft. (28 kg/m ³) Composite Materials: 2 Layers of fabric encapsulating insulation Finished Dimensions: 2 3/4" x 4" x 2 3/4" (70 mm x 102 mm x 70 mm)	<ul style="list-style-type: none"> • 2 layers of fabric insulation • R value of 4.2 • Guard Loc fabric to metal seam • Waterproof • Airtight • Resistant to grease, oil, gasoline and acid



Pat. No. 4103557

INSULFLEX

THERMAFAB UL Classified File# R4462			
ITEM	DESCRIPTION	SPECIFICATIONS (Metric)	FEATURES
#10005 MFT Metallfab	Color: Grey Base Fabric: Woven Fiberglass Coating: Silicon Rubber	Weight: 17 oz./sq. yd. (576 g/sq. meter) Tensile Strength: 200 lbs. x 250 lbs. (889 N x 1120 N) Tear Strength: 50 lbs. x 40 lbs. (222N x 178 N) Low Temp: -65°F (-54°C) High Temp (Continuous): 500°F (260°C)	<ul style="list-style-type: none"> • Excellent high temp. resistance • Excellent low temp. resistance • Excellent chemical resistance • Extremely low smoke emission • Excellent ozone resistance • Excellent resistance to weathering • Unaffected by mildew
#10030 JRT Junior			

- All Duro Dyne Fabrics are designed to meet NFPA 701 (formerly UL 214.)
- All Duro Dyne Fabrics are designed to meet NFPA 90A & 90B.
- All Duro Dyne Fabrics are airtight and waterproof.
- All Duro Dyne Flexible Duct Connector utilize 24 or 28 gauge (.7 mm or .47 mm) galvanized steel meeting ASTM-A-525 G60.
- Standard roll length - 100 ft. (30.48 m)



**DURO
DYNE**

DUCT ACCESS DOORS

Features:

- *22gage galvanized steel construction.*
- *Saves time and is easy to position.*
- *One inch wide gasket frame for fasting and sealing integrity.*
- *Door insulated with one inch thick fiber glass.*

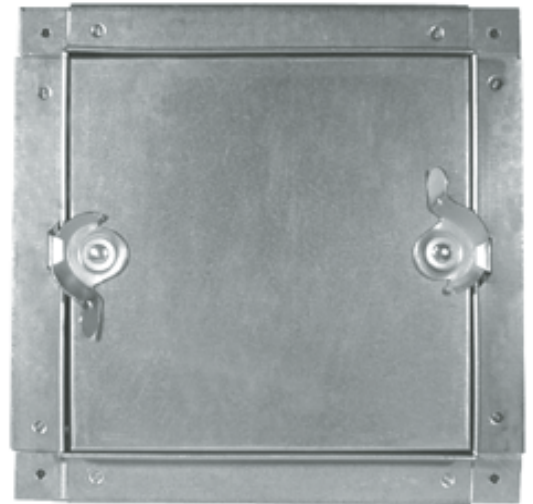

Pre-insulated Ducting Technology:



Duct Technology is a soul agent for PAL MIDDLE EAST PIR. LLC for Pre-insulated Ducting Technology.

PAL complete system technology approach to pre-insulated duct work is the solution to today's air distribution problems.

Features:

- **Cleanable and hygienic.**
- **Environmentally friendly, CFC, HCFC free.**
- **Clean Air: contains no micro fibers.**
- **Light weight: only 15% of sheet metal ducting.**
- **Resistance to fungus growth.**
- **Space saving: flush fitting installation possible.**
- **Low leakage: A fully sealed system conforms to DW 144 class C- high pressure.**
- **Low (U) Value.**
- **Fast track installation.**
- **No limits to duct sizes.**
- **High-compressive strength.**

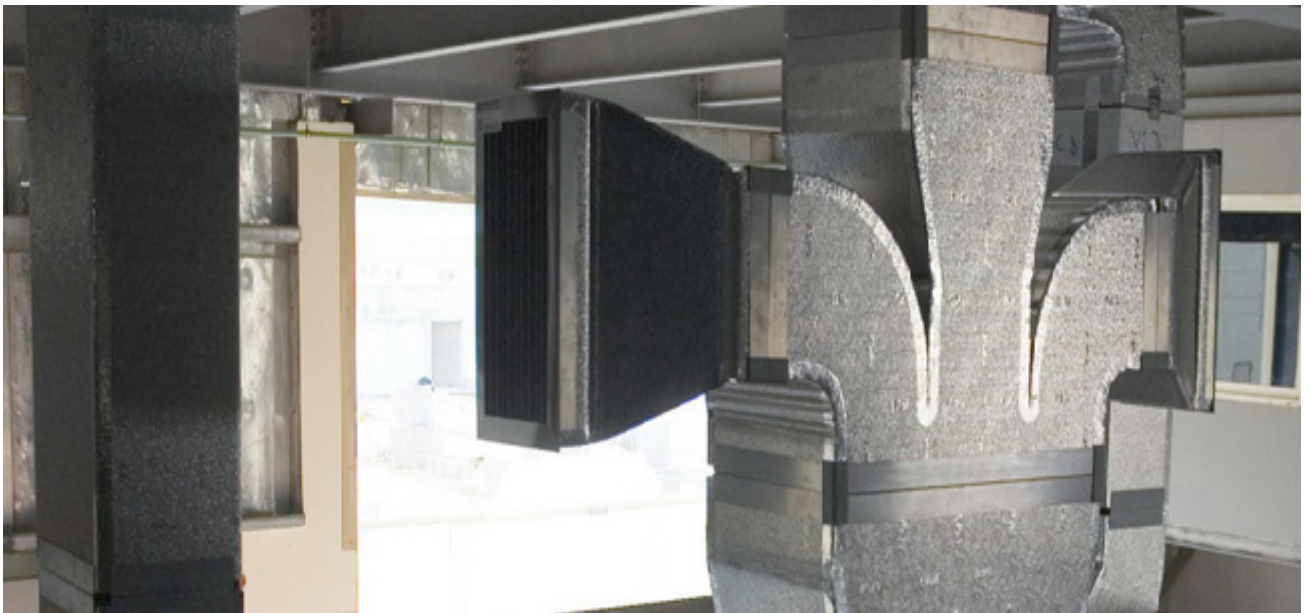

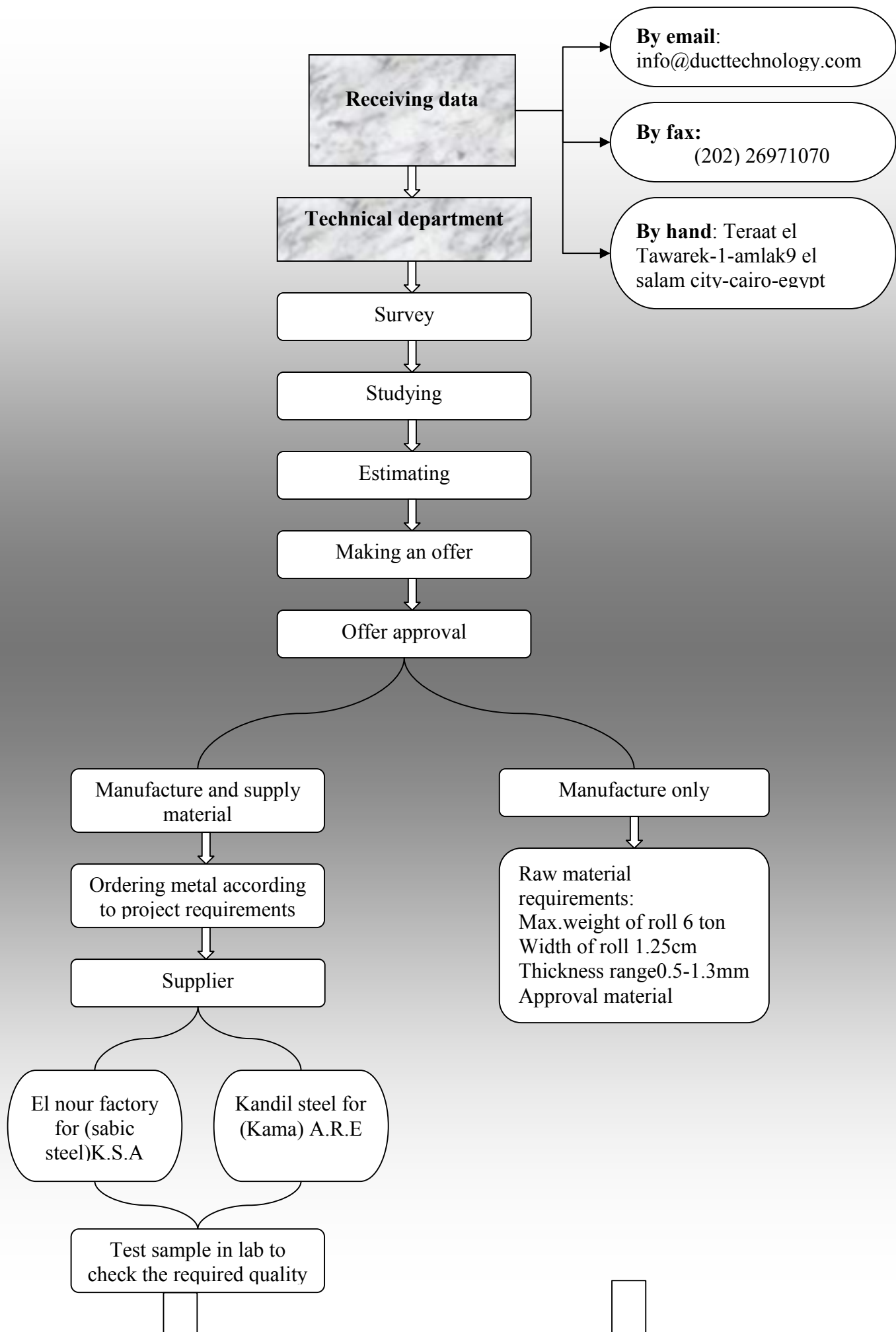

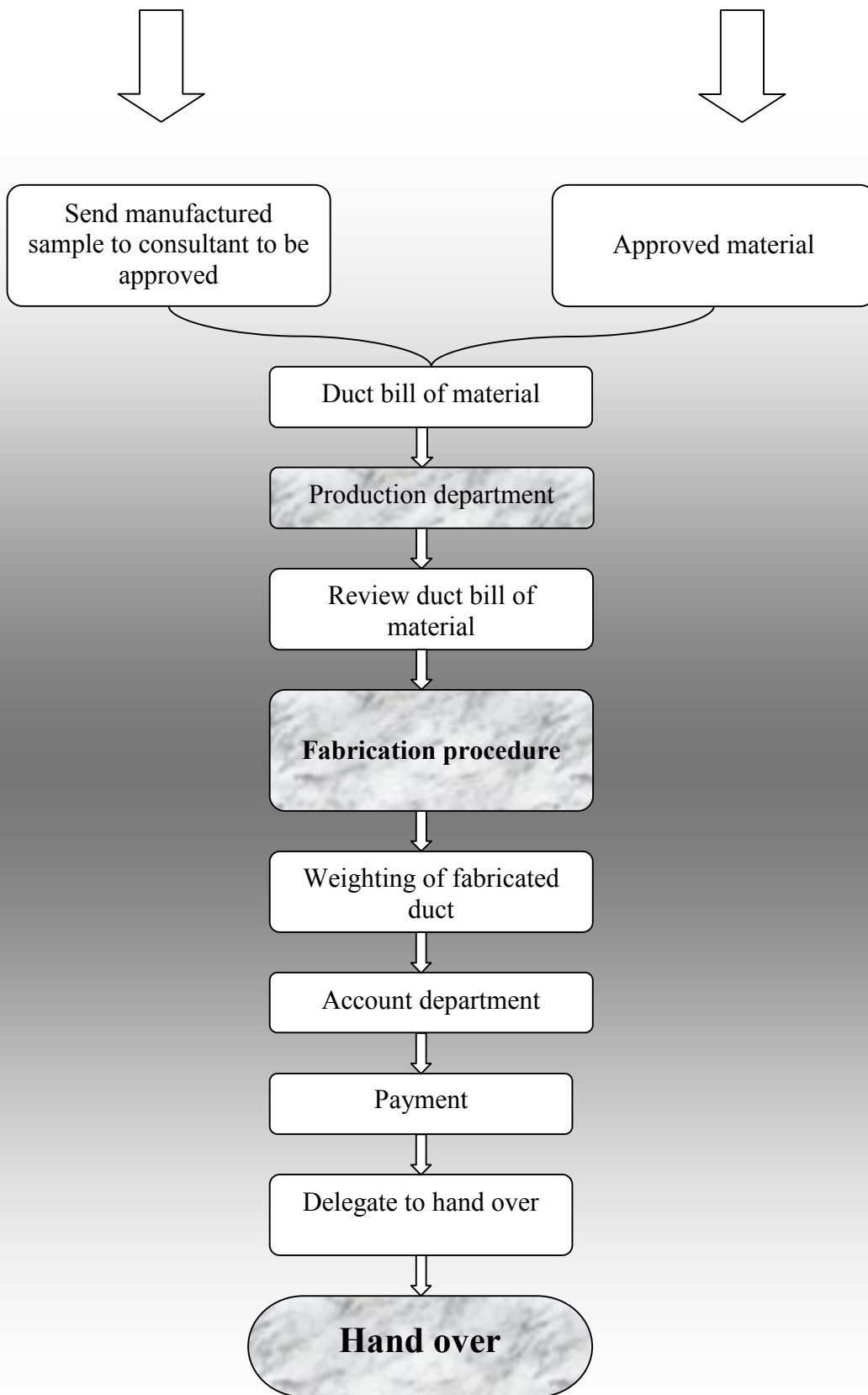

Fabrication procedure

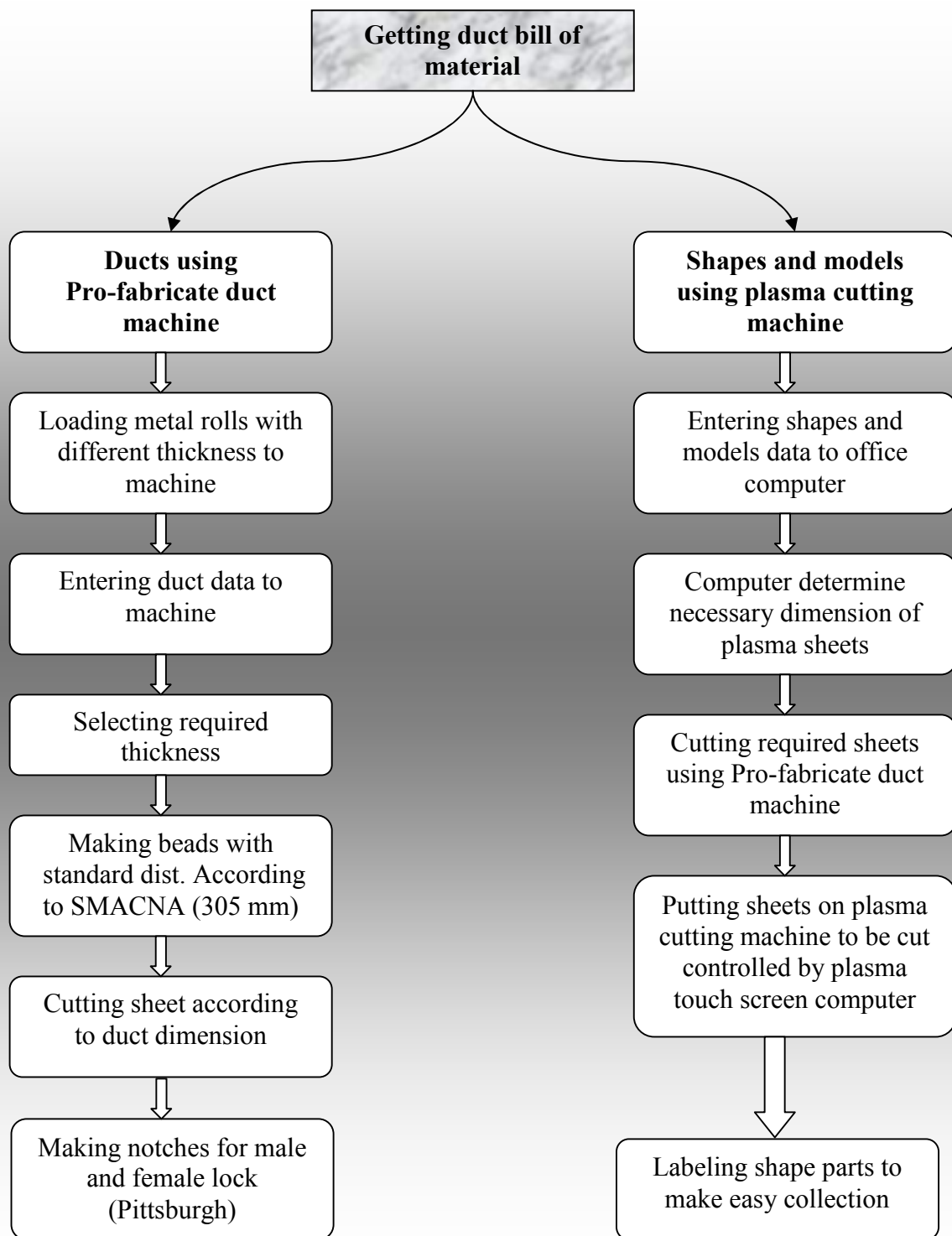

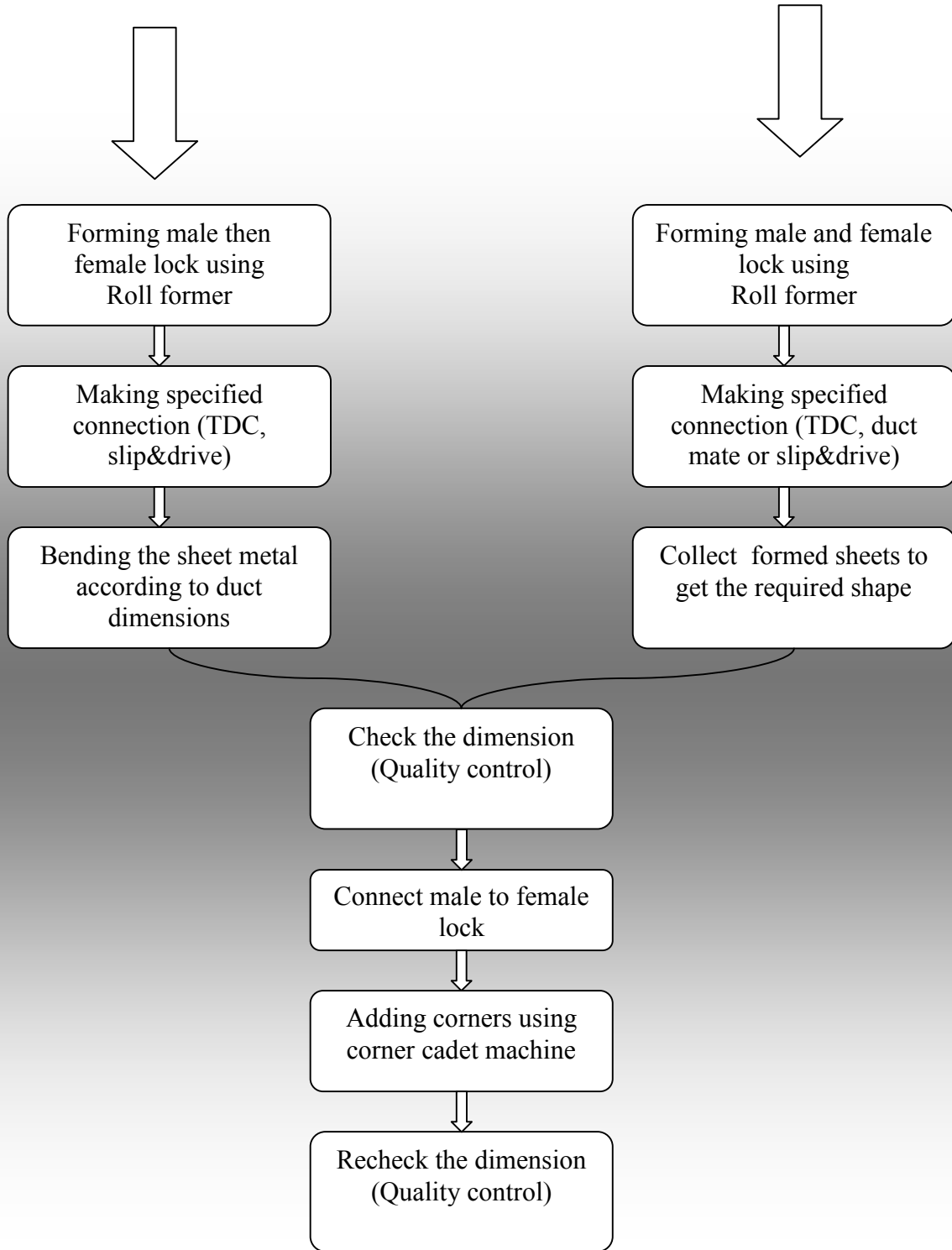

REFERENCE LIST OF PROJECTS

FACTORY

No.	Project	Consultant	location	Quantity	Date	Type	Size
1	Eastern company S.A.E	Infra Group	6th of October City	1600 Ton	2008 2009	slip& drive T.D.C Profile	0-180 inch
2	Fercon factory for car ele. Circuit	T.H.E	6th of October City	80 Ton	2008	Profile	0-80 inch
3	ClothesFactory (POLICE)	Dr.Hakeam Afifi	Suez Road	5 Ton	2009	T.D.C	60 inch
4	Wood Factore (POLICE)	Dr.Hakeam Afifi	Suez Road	2 Ton	2009	T.D.C	80 inch
5	Batatin Factory (POLICE)	Dr.Hakeam Afifi	Suez Road	15 Ton	2009	T.D.C profiles	100 inch
6	El hikma pharma factory	sabbour Associates	6 of oct. industrial zone	25 Ton	2009	T.D.C profiles	0-80 inch
7	Liliy pharma factory	sabbour Associates	6 of oct. industrial zone	10 Ton	2009	T.D.C profiles	0-60 inch
8	ALFA pharma factory	Eng.Khaled El ra'i	Badr industrial zone	20 Ton	2010	slip& drive T.D.C Profile	0-60 inch
9	Future pharma factory	sabbour Associates	Badr industrial zone	90Ton	2010	slip& drive T.D.C Profile	0-60 inch
10	SKIB factory	sabbour Associates	6 of oct. industrial zone	5 Ton	2010	slip& drive	0-60 inch

No.	Project	Consultant	location	Quantity	Date	Type	Size
BUILDING & RESIDENCE							
1	Abou Ghazalah office building	Eng.Sherif Sabry	Smart Village	40 Ton	2007	slip&drive Profile	0-80 inch
2	Al Salam Hospital	Allied Consultants	El Maadi	20 Ton	2008	Profile	0-100 inch
3	British Council	Archimid Architectures "Glenn Patten & Asmaa El Goweni"	El Agouza	5 Ton	2009	slip&drive	
4	British Embassy	John Vent	Garden City	5 Ton		slip&drive	
5	Egypt Cyber Center	Ph.D.Ahmed ElAssey Ein Shams University	6th of October City			slip&drive	
6	Kasr El Einey	Siemens	Kasr El Einey			slip&drive	
7	EBB	Eng.Sherif Sabry	Mohandessein			slip&drive	
8	Police Club	M.T.Dr. M.Eldaly	El Guezira			slip&drive	
9	Sayed Darwish Theatre	Allinet (Hassan Allam sons)	Alex.			slip&drive	
Companies							
1	Honda show room	Yehia Hegazy /Medhat Abu Zeid	New Cairo City	35 Ton	2007	slipe&drive Iron angles	0-100 inch
2	Vodafone Headquarter	Dr. Essam Khalil	6th of October City	40 Ton	2008	Profile	
3	47 Office Bldg. Project	Eng.Sherif Sabry	5 Th district - New Cairo	10 Ton	2008	slipe&drive Profile	
4	Maersk	Crown Home	City Stars, Cairo			slip&drive	
5	Alnaeem	EMG	Lebanon Str.			slip&drive	
6	Motorola	EMG	Nile City			slip&drive	
7	IFC	Crown Home	Nile City			slip&drive	
8	Conference Room	Crown Home	IFC Company, Nile City			slip&drive	
9	D H L	2 Wires	Sheraton			slip&drive	

10	LUKOIL	2 Wires	Maadi			slip&drive	
11	Gironil	2 Wires	Maadi & Post			slip&drive	
12	Egyptian Liquefied Narural Gas Project. (ELNG)	Allinet (BECHTELL Company)	Rasheed& Edco			slip&drive	
13	British Airways	John Vent	Down Town			slip&drive	

BANK

1	Audi Bank	Mounir Saroufim	Lebnan	1.5 Ton		slip&drive	
2	BNP Bank	Eng.Sherif Sabry	El Suez	1.5 Ton		slip&drive	
3	NSGB	Eng.Sherif Sabry	Maadi	1.5 Ton		slip&drive	
4	HSBC Bank	Eng.Sherif Sabry	El Mesaha	2 Ton		slip&drive	
5	HSBC Bank	Eng.Sherif Sabry	Obbour Branch	3 Ton		slip&drive	2007
6	Arab Bank	ECG	Zamalek	2 Ton		slip&drive	2008
7	CIB Bank	Archimid Architectures "Glenn Patten & Asmaa El Goweni"	Alex.	3Ton		slip&drive	
8	CIB Bank	Sherif Sabry & Sami El Hadary	Abbassia	2 Ton		slip&drive	
9	CIB Bank	Crown Home	El Thawrah	2 Ton		slip&drive	
10	CIB Bank	Crown Home	El Mohandssein	3Ton		slip&drive	
11	CIB Bank	Eng.Tarek Fathy	Giza	2 Ton		slip&drive	
12	CIB Bank	Eng.Sherif Sabry	City Stars, Cairo	1 Ton		slip&drive	
13	Barclays Bank	Moharam Bakhoum	City Stars, Cairo	1.5 Ton		slip&drive	
14	Barclays Bank	Moharam Bakhoum	Alex. Roshdy	2 Ton		slip& drive	

15	Barclays Bank	Moharam Bakhoum	Alex. Loran	2 Ton		slip&drive	
16	Barclays Bank	Moharam Bakhoum	10th of Ramadan City			slip&drive	
17	Barclays Bank	Moharam Bakhoum	6th of October City			slip&drive	
18	Barclays Bank	Moharam Bakhoum	Mansoura			slip&drive	
19	Barclays Bank	E HAF	Abbas El Akad			slip&drive	
20	Barclays Bank	Eng.Ashraf Sadek	Port Said			slip&drive	
21	Audi Bank	Mounir Saroufim	Shams			slip&drive	
22	Audi Bank	Mounir Saroufim	Lebnan			slip&drive	
23	Credit Swiss Bank	C.G.E.S.	Nile Tower			slip&drive	
24	Cairo Bank Complex	Shaker Group	Salah Salem			slip&drive	
25	HSBC Bank	Eng.Sherif Sabry	Alex.			slip&drive	
26	HSBC Bank	Eng.Sherif Sabry	City Stars, Cairo			slip&drive	
27	HSBC Bank	Eng.Sherif Sabry	New Maadi , El Nasr Str.			slip&drive	
28	HSBC Bank	Eng.Sherif Sabry	Sphinx Branch			slip&drive	
29	HSBC Bank	Eng.Sherif Sabry	Nasr City Branch			slip&drive	

Duct Technology Machines

No.	Machine	Quantity	Image
1	Pro-fabricate duct machine	1	
2	Plasma cutting machine Vulcan 1000D	2	
3	TDC flange forming machine	1	
4	Pittsburgh lock former	5	
5	Standing "S" Cleat	1	

Duct Technology Machines

6	Corner Cadet	2	 A blue and black manual corner cutting machine with a long handle and a circular cutting head.
7	Hydraulic fastener	1	 A blue and black hydraulic tool with a long handle and a clamping mechanism.
7	Hand folder	2	 A blue manual hand folder machine with a large wheel and a cutting edge.
8	Hydraulic folder	1	 A green hydraulic folder machine with a large cutting edge and a control panel.
9	Motor-driven shear	2	 A blue motor-driven shear machine with a large cutting edge and a motor.
10	Hand shear	3	

Duct Technology Machines

11	Elbow maker machine	1	
12	Stitch welder	1	
13	Electrical-driven bending machine	1	
14	Hand bending machine	1	
15	Aluminum flexible duct forming machine	1	

Duct Technology Machines

16	Motor rotary machine	1	
17	Rotary machine	1	
18	Whisper-loc seam closer	2	
19	CNC Press brake	1	
20	Drilling machine	1	
21	TDC corner production line	1	

Duct Technology Machines

22	C-channel machine	1	
23	Core machine	1	
24	Forklift	6	
25	Loader	1	
26	(TIG) Welding Machine	1	
27	Scissors 6m	3	

Duct Technology Machines

28	Scissors 8m	1	
30	Fork Left	6	

No.	Machine	Quantity
1	Pro-fabricate duct machine	1
2	Plasma cutting machine Vulcan 1000D	2
3	TDC flange forming machine	1
4	Pittsburgh lock former	5
5	Standing "S" Cleat	1
6	Hydraulic fastener	1
7	Hand folder	2
8	Hydraulic folder	1
9	Motor-driven shear	2
10	Hand shear	3
11	Elbow maker machine	1
12	Stitch welder	1
13	Electrical-driven bending machine	1
14	Hand bending machine	1
15	Aluminum flexible duct forming machine	1

16	Motor rotary machine	1
17	Rotary machine	1
18	Whisper-loc seam closer	2
19	CNC Press brake	1
20	Drilling machine	1
21	TDC corner production line	1
22	C-channel machine	1
23	Core machine	1
24	Forklift	6
25	Loader	1

Organization Chart

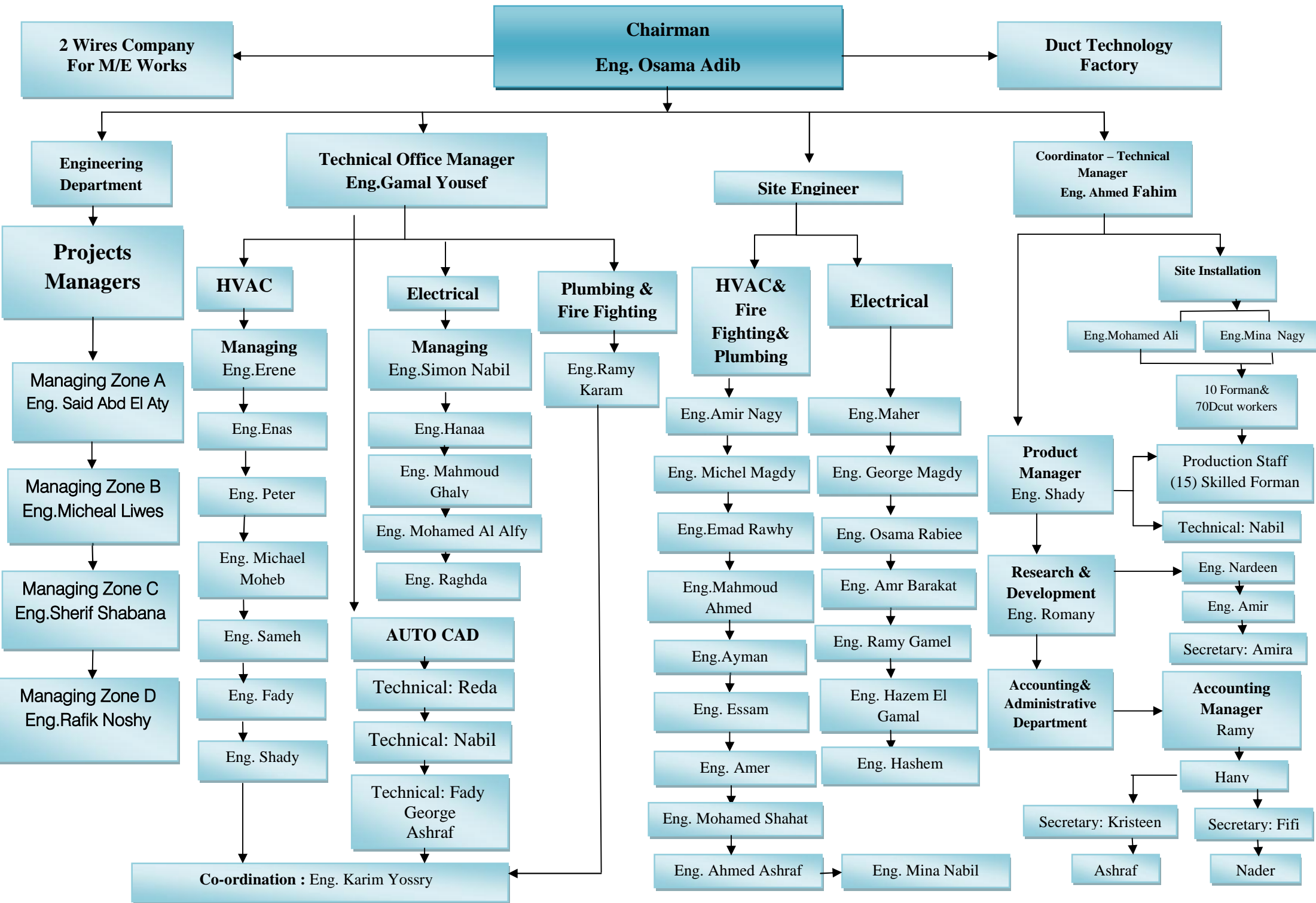

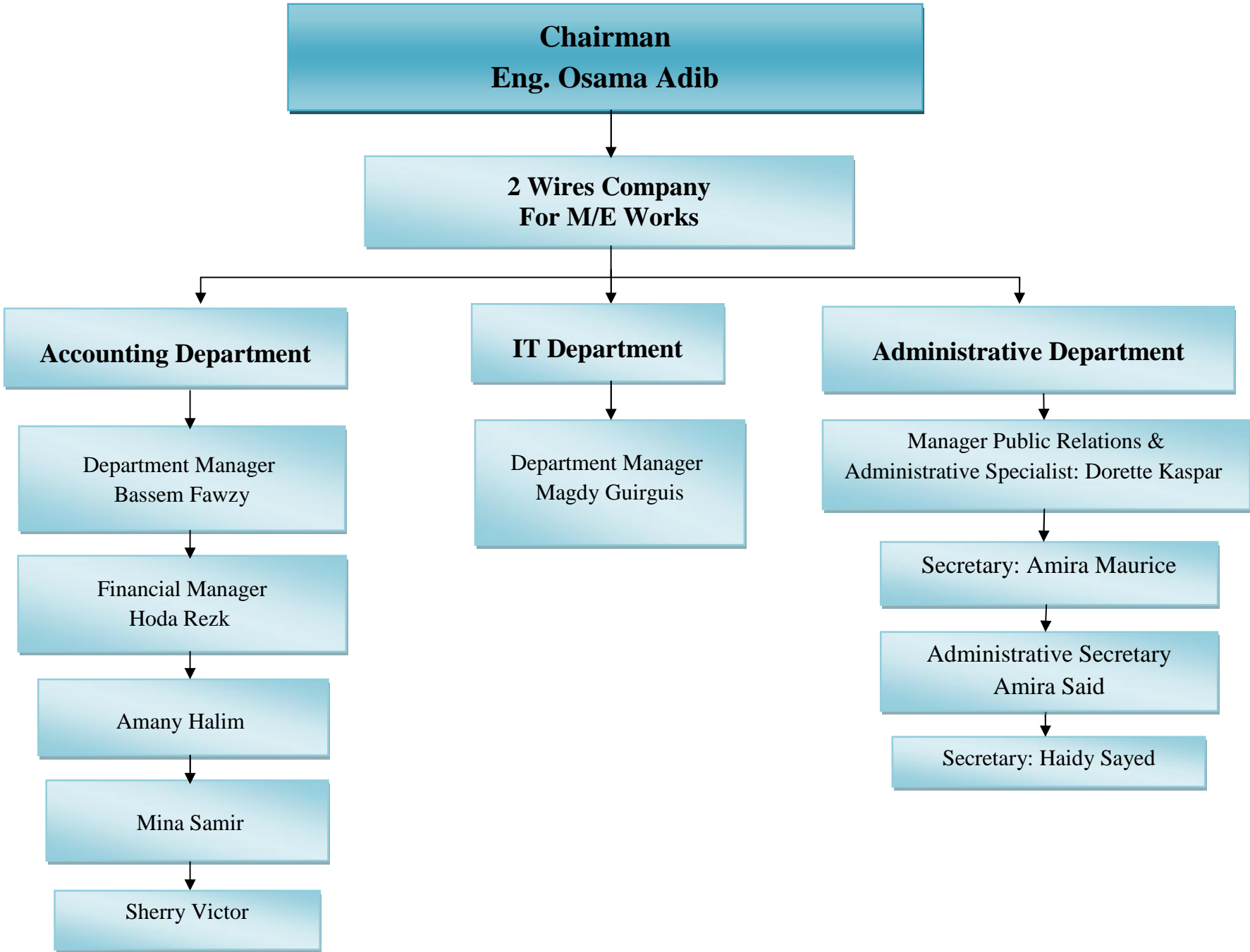

Scop Of Engineering Service

Electromechanical Works

Mechanical

Electrical



- Steel & Metal Works
- HVAC & B.M.S
- Fire Fighting
- Plumbing
- Cold Stores
- Mechanical Testing & Commissioning

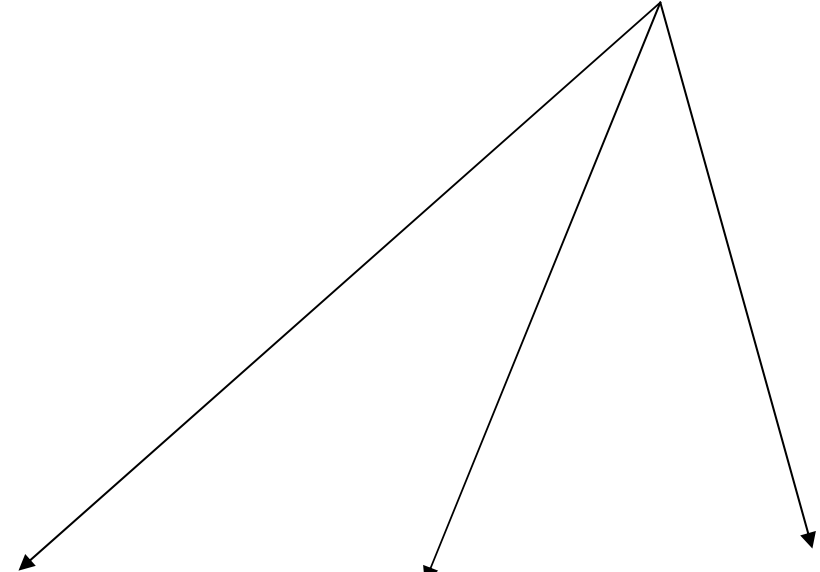

Medium Voltage

Low Voltage

Light Current

- 1- Ring main Unit Power
- 2- Transformer Emergency
- 3- Generator
- 4- Bus Bar Feeders

- 1- Power & Lighting
- 2- Main Distribution Board
- 3- Panel Boards
- 4- Cable & Cable Tray

- 1- Fire Alarm System
- 2- CCTV System
- 3- Public Address System
- 4- Access & Intrusion System
- 5- SMATV System
- 6- Telephone & Data System

List of Projects

I : Banks :

Citi Bank Head Office : Boomerang Bldg , New Cairo, Egypt.
Main Branch : Garden City & Alex,,: Semouha Branch



CIB Bank Alex Semoha Branch, Abbassia, El Thawrah , El Mohandessein , Giza & City Stars Cairo



Barclays Bank City Stars Cairo, Alex. Rushdiy, Alex. Loran
10th of Ramadan CitY, 6th of October City, Mansoura,
Abbas El Akad & Port Said



■ **HSBC** City Stars



Audi Bank	Shams, Lebnan
Credit Swiss Bank	Nile Tower
Cairo Bank Complex	Salah Salem
BNP Bank	El Suez
NSGB	Maadi
Arab Bank	Zamalek
HSBC Bank	El Mesaha, Haipar One , Alex., City Stars Cairo , New Maadi El Nasr Str., Sphinx Branch Aboul Feda Bldg. Zamalek, Nasr City Branch & Obbour Branch



II : Company :

Honda	New Cairo City
Vodafone Headquarter	6th of October City
Maersk	City Stars, Cairo
IT Works	Free Zone
ACRO	El Maadi
Alnaeem	Lebnan Str.
Motorola	Nile City
IFC	Nile City
Conference Room	IFC Company, Nile City
Mobinil	Mansoura
D H L	Sheraton
LUKOIL	Maadi
Gironil	Maadi & Post

Egyptian Liquefied Natural Gas Project. (ELNG) Rasheed & Edco

British Airways Down Town

Administrative Control Authority Alex.

Price Water House 5th district - New Cairo

Vodafone Maddi

47 Office Bldg. Project 5th district - New Cairo



Vehicle Components Industries Engineering Division (Ghabbour)

Elsadat City



ABC Leasing Office Building

Smart Village



III : Factory :

Alcoa Factory	6th of October City
Proctel & Gamble Factory " P & G	6th of October City
Bel Egypt, Cairo Factory	10th of Ramadan City
Adfy Foam Factory	Elsadat City
Bench Mark Factory	Badr City
El Natrun Valley Factory	Cairo,Alex.Desert Rd.
P&G (Factory&Head Office)	6th October&Nile City
Eastern Company S.A.E	6th of October City



Fercon Factory

6th of October



Police Factory (Clothes , Wood, Batatin)



IV : BUILDING & RESIDENCE :

Abou Ghazalah	Smart Village
British Council	6th of October City
Rekaba El-Edareya	Alex.
El Ezz Show Room	Nasser City
Conference Room	British Council, El Agouza
Banha University	Banha
Saridar Building	Dokki
British Embassy	Garden City
Al Salam Hospital	El Maadi



Kasr El Einey	Kasr El Einey
El Hossein Hospital	El Hossein
EBB	Mohandessein
Police Club	El Guezira
Sayed Darwish Theatre	Alex.
Villa El Miniawy	6th October City
El Gawhara villa	El Agouza
Assala (Flat)	El Maadi
Dar Al Wthaaek	Old Cairo - El Fostat

V : HOTEL :

Mena House



El Haram



Harmony Resort

Hurghada

Soffitel Hotel

Cairo

Helnan Shepheard Hotel

Cairo

REFERENCE LIST OF PROJECTS & CONSULTANTS

No.	Project	Consultant	location
I : BANK			
01	Citi Bank - Head Office	Allied Consultants	Boomerang Bldg. New Cairo, Egypt
02	Citi Bank - Main Branch	PH.D.C.E.B E.E Khalil	Garden City
03	Citi Bank	Allied Consultants	Alex. - Semouha Branch
04	Citi Bank	Allied Consultants	El Mohandssein
05	CIB Bank	Archimid Architectures "Glenn Patten & Asmaa El Goweni"	Alex.
06	CIB Bank	Sherif Sabry & Sami El Hadary	Abbassia
07	CIB Bank	Crown Home	El Thawrah
08	CIB Bank	Crown Home	El Mohandssein
09	CIB Bank	Tarek Fathy	Giza
10	CIB Bank	Sherif Sabry	City Stars, Cairo

REFERENCE LIST OF PROJECTS & CONSULTANTS

No.	Project	Consultant	Location
11	Barclays Bank	Moharam Bakhoum	City Stars, Cairo
12	Barclays Bank	Moharam Bakhoum	Alex. Roshdy
13	Barclays Bank	Moharam Bakhoum	Alex. Loran
14	Barclays Bank	Moharam Bakhoum	10 th of Ramadan City
15	Barclays Bank	Moharam Bakhoum	6 th of October City
16	Barclays Bank	Moharam Bakhoum	Mansoura
17	Barclays Bank	E HAF	Abbas El Akad
18	Barclays Bank	Ashraf Sadek	Port Said
19	Barclays Bank	Sherif Sabry	El Haram
20	Audi Bank	Mounir Saroufim	Shams
21	Audi Bank	Mounir Saroufim	Lebnan
22	Credit Swiss Bank	C.G.E.S.	Nile Tower
23	Cairo Bank Complex	Shaker Group	Salah Salem
24	BNP Bank	Sherif Sabry	El Suez

REFERENCE LIST OF PROJECTS & CONSULTANTS

No.	Project	Consultant	location
25	NSGB	Sherif Sabry	Maadi
26	HSBC Bank	Sherif Sabry	El Mesaha
27	HSBC Bank	Sherif Sabry	Haipar One
28	HSBC Bank	Sherif Sabry	Alex.
29	HSBC Bank	Sherif Sabry	City Stars, Cairo
30	HSBC Bank	Sherif Sabry	New Maadi , El Nasr Str.
31	HSBC Bank	Sherif Sabry	Sphinx Branch
32	HSBC Bank	Sherif Sabry	Aboul Feda Bldg. Zamalek
33	HSBC Bank	Sherif Sabry	Nasr City Branch
34	HSBC Bank	Sherif Sabry	Obbour Branch
35	Arab Bank	ECG	Zamalek
36	AWB	Al Attar & Medic	5 th District –New Cairo
37	NBD	Allied	Omar Makram –Down Town
38	Piraeus	MED	Zamalek
39	Credit Agricole	Eng. Hany Fawzy	Zamalek

REFERENCE LIST OF PROJECTS & CONSULTANTS

No.	Project	Consultant	location
40	Audi Bank	Mounir Saroufim	Pyramids Heights C8
41	Audi Bank	Mounir Saroufim	Pyramids Heights C5
42	CIB-Black Ball	EGICO	5th District New Cairo)
43	Barclays	Moharam Bakhoum	El Haram
44	Barclays	Moharam Bakhoum	El Maadi
45	Credit Agricole	Zewar	Zamalek
46	Mashreq Bank	Pacer	El Sheikh Zayed

REFERENCE LIST OF PROJECTS & CONSULTANTS

No.	Project	Consultant	location
II : COMPANY			
01	Honda	Yehia Hegazy / Medhat Abu Zeid	New Cairo City
02	Vodafone Headquarter	Dr. Essam Khalil	6 th of October City
03	Maersk	Crown Home	City Stars, Cairo
04	IT Works	T.H.L.	Free Zone
05	ACRO	Albonian	El Maadi
06	Alnaeem	EMG	Lebnan Str.
07	Motorola	EMG	Nile City
08	IFC	Crown Home	Nile City
09	Conference Room	Crown Home	IFC Company, Nile City
10	Mobinil		Mansoura
11	D H L	2 Wires	Sheraton
12	LUKOIL	2 Wires	Maadi
13	Gironil	2 Wires	Maadi & Post
14	Egyptian Liquified Narural Gas Project. (ELNG)	Allinet (BECHTELL Company)	Rasheed & Edco

REFERENCE LIST OF PROJECTS & CONSULTANTS

No.	Project	Consultant	location
15	British Airways	John Vent	Down Town
16	Administrative Control Authority	Tarek Fathy	Alex.
17	47 Office Bldg. Project	Sherif Sabry	5 th District - New Cairo
18	Price Water House	Modern Interiors	5 th District - New Cairo
19	Vehicle Components Industries Engineering Division (Ghabbour)	Magdy Nessem	El Sadat City
20	Vodafone	Crown Home	El Maadi
21	ABC Leasing Office Building	EMDEG (Magdy Kamel)	Smart Village
22	Etisalat	Etisalat (Eng. Hamada Youssry)	Smart Village
23	Raya	Dr. Shaker	6 th of October City
24	Intel	ECG	El Maadi

REFERENCE LIST OF PROJECTS & CONSULTANTS

No.	Project	Consultant	Location
III : FACTORY			
01	Alcoa Factory	A.P.M.	6 th of October City
02	Eastern Company S.A.E	Infra Group	6 th of October City
03	Procter & Gamble Factory " P & G "	Archimid Architectures "Glenn Patten & Asmaa El Goweni"	6 th of October City
04	Bel Egypt, Cairo Factory	A.P.M.	10 th of Ramadan City
05	Fercon	The - Eng. Ahmed Khatab	6 th of October City
06	Adfy Foam Factory	Kamal Mostafa	El Sadaat City
07	Bench Mark Factory	Engineering Group	Badr City
08	El Natrun Valley Factory	2 Wires	Cairo,Alex.Desert Rd.
09	P&G (Factory&Head Office)	Dr. Ahmed Nour	6 th October&Nile City
10	Clothes Factory	Dr. Hakeam Afifi	Suez Road

REFERENCE LIST OF PROJECTS & CONSULTANTS

No.	Project	Consultant	location
11	Wood Factory	Dr. Hakeam Afifi	Suez Road
12	Batatin Factory	Dr. Hakeam Afifi	Suez Road
13	Thinner , paints &Shoes	Dr. Hakeam Afifi	Suez Road
14	Future Pharmaceutical Factory	Hussein Sabbour	6 th of October City
15	Lilli Pharmaceutical Factory	Howeedy Consultant	6 th of October City
16	Hikma Pharmaceutical Factory	Saleh & Hegab Consultant	6 th of October City
17	Alpha Pharmaceutical Factory	System Design Eng. Khaled El Rayee	6 th of October City
18	Edita Confectionery Industries Factory	Al Amar Consulting Group S.A.	Beni Swaif
19	Edita Factory	Edita Co.	6 th of October City
20	Edita Factory	Edita Co.	10 th Of Ramadan
21	Naseej Company	Eng. Ashraf Kamel	5 th District New Cairo

REFERENCE LIST OF PROJECTS & CONSULTANTS

No.	Project	Consultant	Location
IV : BUILDING & RESIDENCE			
01	Abou Ghazalah	Sherif Sabry	Smart Village
02	Al Salam Hospital	Allied Consultants	El Maadi
03	British Council	Archimid Architectures "Glenn Patten & Asmaa El Goweni"	El Agouza
04	Egypt Cyber Center	Ph.D. Ahmed El Assey Ein Shams University	6 th of October City
05	Rekaba El-Edareya	Tarek Fathy	Alex.
06	El Ezz Show Room	PH.D. Shaker Group	Nasser City
07	Conference Room	Ova Arub	British Council, El Agouza
08	Banha University	Faculty of Engineering	Banha
09	Saridar Building	Ph.D.C.E.B E.E Khalil	Dokki
10	British Embassy	John Vent	Garden City
11	Kasr El Einey	Siemens	Kasr El Einey

REFERENCE LIST OF PROJECTS & CONSULTANTS

No.	Project	Consultant	location
12	El Hossein Hospital	Siemens	El Hossein
13	EBB	Sherif Sabry	Mohandessein
14	Police Club	M.T. Dr. M.Eldaly	El Guezira
15	Sayed Darwish Theatre	Allinet (Hassan Allam Sons)	Alex.
16	Villa El Miniawy	2 Wires	6 th October City
17	El Gawhara villa	Dr. Ehab Ezzat	El Agouza
18	Assala (Flat)	2 Wires	El Maadi
19	Villa Ehab & Omar	THE	5 th District –New Cairo
20	Carrefour Hyper Market	Pacer	Alex.
21	Dar Al Wthaaek	Crown Home - Ahmed Tag	Old Cairo - El Fostat
22	El Hanager	Dr. Hakeam Afifi	Cairo Opera House

REFERENCE LIST OF PROJECTS & CONSULTANTS

No.	Project	Consultant	location
23	Carrefour Express	Pacer	Mokattam
24	Zezenia Mall	Concept Dr. Hassan Ahmed Elzomaly	El Haram
25	Carrefour Sun City	Pacer	Sheraton
26	Ballroom Police Club	Dr. Hakim Afifi	El Gizira – Down Town
27	Building Hotel Suites Police Club	Dr. Hakim Afifi	El Gizira – Down Town
28	Garage Police Club	Dr. Hakim Afifi	El Gizira – Down Town
29	Carrefour Hyper Market	Pacer	Orouba Mall Alex.
30	Carrefour Hyper Market	Pacer	El Maadi
31	Carrefour Hyper Market Sky Plaza Mall	Pacer	El Shourouk City
32	St. Mary Church	Dr. Ramdan Ameer	Helwan
33	St. George Church	Magdey Rafla	El Fayoum

REFERENCE LIST OF PROJECTS & CONSULTANTS

No.	Project	Consultant	location
34	St. Mark Church Service Building	Magdey Rafla	Cleopatra
35	ALSTOM New Premises	BECT (Bureau Egyptien de Conseils Techniques)	5th District –New Cairo
36	Peugeot Rapide	MA Consultant	Katamya
37	Community Mall	-	El Sheikh Zayed

REFERENCE LIST OF PROJECTS & CONSULTANTS

No.	Project	Consultant	location
V: HOTEL			
01	Mena House	Dr.Shaker	6 El Haram
02	Harmony Resort	2Wires	Hurghada
03	Soffitel Hotel	2 Wires	Cairo
04	Helnan Shepheard Hotel	2 Wires	Cairo
05	Zoser	Amer Consulting Mechanical	Hurghada
06	Rohanou Resort	Magdey Rafla	Hurghada
07	Hilton El-Zamalek Residence Cairo	ECE-Elite Consolidated	El Zamalek

References

Recommendation Certificates

TO WHOM IT MAY CONCERN

This is to certify that **Two Wires** has successfully completed the electric & low current works for Citibank office building at new Cairo project.

Two Wires has shown a great level of cooperation and technical professionalism in Citiplan project.

Two Wires contribution was instrumental to overall success of the project. We highly recommend them.

This certificate has been issued upon Two Wires request with no responsibility to our firm.

Citibank N. A, Egypt

Ahmed Azmi
Projects Manager

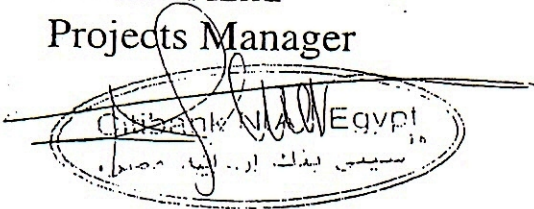



To whom it may concern

Uhde GmbH, a member of the ThyssenKrupp group of companies, is contracted by EPPC to construct an PDH/PP Complex Factory in Port Said, Egypt.

During the period of commissioning work of the HVAC systems **Two Wires** has successfully completed the Air flow Measurements of the different HVAC systems.

The work showed the application of technical and quality standards. **Two Wires** proved to be experienced, co-operative and capable to emit the assigned responsibilities.

Our joint work and meetings are impressed by a fruitful and successful co-operation atmosphere on an high technical level standard.

Due to the quality of Air flow Measurements we highly recommend them.

This certificate has been issued upon **Two Wires's** request with no responsibility to our company.

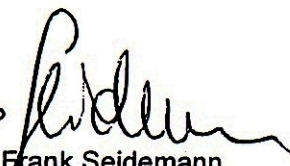
9.7.2010 
Dr. Frank Seidemann
Lead Engineer HVAC



TO WHOM IT MAY CONCERN

We advise that Two Wires has successfully completed the Electromechanical Works For the following projects:

IFC - 24th Floor - Nile City
IFC - 25th Floor - Nile City
MAFRSK - City Stars
CIB - Mohandessin

Completed on April 2006
Completed on August 2006
Completed on August 2006
Completed on May 2007

The Works have been completed according to the Specifications and to the Satisfaction of the Consultant and the Client.

Signature

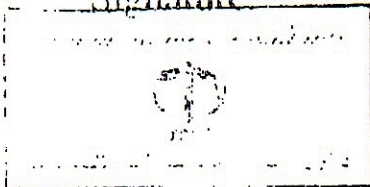

BARCLAYS

بنك باركليز - مصر

١٢ ميدان الشيخ يوسف
جاردن سيتي
ص ب ١١٠ مجلس الشعب
القاهرة مصر

تليفون (٢٠٢) ٢٣٦٦٢٠٠
تلكس CABAR UN ٩٢٣٤٣ - ٩٢٣٤٣
تلكس (٢٠٢) ٢٣٦٦٢٨١١ - ٢٣٦٦٢٨١١

Barclays Bank - Egypt S.A.E

12 Midan El Sheikh Youssef
Garden City
PO Box 110 Maglis El Shaab
Cairo Egypt

Tel (202) 23662600
Telex 92343 & 93734 CABAR UN
Fax (202) 23662810 - 23662811
www.barclays.com

TO WHOM IT MAY CONCERN

*We advise that Two Wires Eng (Ossama Adib)
Representative has successfully completed the
Electromechanical Works For the following projects as a
subcontractor from the general contractor conserv:*

Barclays Bank- City Star Branch
Barclays Bank- Mansoura Branch
Barclays Bank- 6 the of October Branch
Barclays Bank - Alexandria Loran Branch
Barclays Bank - Alexandria Roshde Branch
Barclays Bank - Alexandria 10th of Ramadan Branch
Barclays Bank - Mohandsen Branch

The Works have been completed according to the Specifications and to the Satisfaction of the Consultant and the Client.

Bank Barclays,

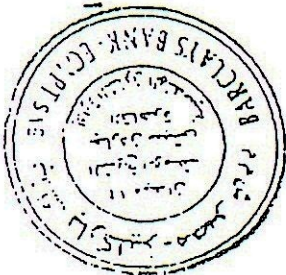

E . M . C

ELECTRO - MECHANICAL CONSULTATIONS.
ELEC . CONSULTANT / M . SAMI EL - HADARY.

مكتب التصميمات والإستشارات الكهروميكانيكية
مهندس إستشاري / محمد سامي الحضري

TO WHOM IT MAY CONCERN

We advise that Two Wires has successfully completed the Electromechanical Works For the following projects:

cyber Center	Egypt Branch
IB	Giza Branch
IF	Alexandria Branch
SCIB	Obera Branch
ENB	El Suez Branch
BNB	Luxor Branch
ISBC	El Mesaha Branch
ISBC	Alexandria Branch

The Works have been completed according to the Specifications and to the Satisfaction of the Consultant and the Client.

E. H. Sami

ELEC . CONSULTANT
M . SAMI EL - HADARY.

25-8-2007



TO WHOM IT MAY CONCERN

We advise that Two Wires Eng (Sherif shabana) Representative has successfully completed the Electromechanical Works For the following projects as a subcontractor from the general contractor conserv:

- Barclays Bank- City Star Branch
- Barclays Bank- Mansoura Branch
- Barclays Bank- 6 the of October Branch
- Barclays Bank - Alexandria Loran Branch
- Barclays Bank - Alexandria Roshde Branch
- Barclays Bank - Alexandria 10th of Ramadan Branch
- Barclays Bank - Mohandsen Branch

The Works have been completed according to the Specifications and to the Satisfaction of the Consultant and the Client.

Bank Barclays,

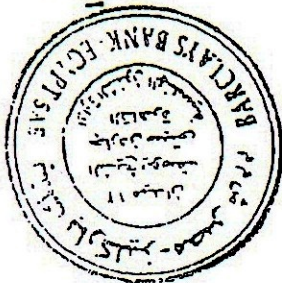

Egypt & Middle East

Import - Export Ltd. Co.

Capital 50 000 000 L.E.-Paid up Capital 17 010 000 L.E.
Commercial Register 292539 - Tax Card No. 6434 P.L.C.

TO WHOM IT MAY CONCERN

We advise that Two Wires has successfully completed the Electromechanical Works For the following projects:

- ❖ Administrative Control.
- ❖ Faculty of Commerce – Banha.
- ❖ IT Works.
- ❖ Building the Full Legal Advice.
- ❖ Village Harmony – Hurghada.

The Works have been completed according to the Specifications and to the Satisfaction of the Consultant and the Client.

Signature

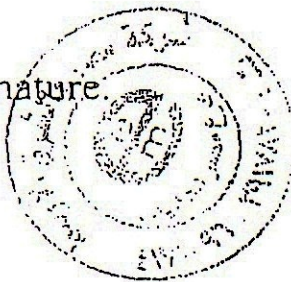

Sole Agencies



Office Equipments
- National Panasonic
Plain paper photocopier
- National Panasonic
Facsimile Machines
- IBM *
Electronic Typewriters



Telephone Systems
Samsung
Aiphone
Alkatel (GSM)*



Sound System
Banyer



Light System
G. Amirata



Air Conditioners
Miraco - Carrier*
Airflow



Fire Fighting Equip.
Taiyo Russian
C - Tec
ASCOA



Medical Equipments
ERBE
Vitalograph
Vacumed
MIE



Traffic & Safety Equip.
3M *
Code 3
Kustom



Satellite System
Orbitron *

* Distributors

Branches

P.O.Box : 1765

Fax : 2910028

General
Management
Down Town
Sales Branch
Cairo

117 EL Thawra st.
G2 Lebanon sq.
10 Sayed Darwish st., Tawfikia
20 Karibay st., Ismailia sq.
187 Ramsis st.
10 Ahmed Said st.
7 El Merghany st.

Tel.: 2913133
Tel.: 3447989
Tel.: 5749205
Tel.: 4177261
Tel.: 5904978
Tel.: 4829743
Tel.: 2584832

Alexandria
Tanta
Ismailia
Assiout
Luxor
Minia
Zagazik

: 64 Soter st. Azarita
: 2 Sedki st.
: 10 El Tamluk st., El Sheikh Zaid sq
: 13 El Kamak st.
: Madina Monawara & El Horia st., El Awamia
: 2 El Shohada st.
: 35 Nadi El Moalmeen A st.

Tel.: 4865265
Tel.: 3303103
Tel.: 329486
Tel.: 330570
Tel.: 370315
Tel.: 346664
Tel.: 354495

**LUKOIL**

OVERSEAS EGYPT LTD.

لوك اويل
أوفرسيز إيجيبت ليمتد

TO WHOM IT MAY CONCERN

We advise that Two Wires Eng (Sherif shabana) Representative has successfully completed the Electromechanical Works For:-

Lukoil overseas Egypt LTD CO.
78 ELsharefa dina st .maadi Branch.egypt.

The Works have been completed according to the Specifications and to the Satisfaction of the Consultant and the Client.

Signature.

AHC Co.
Advanced HVAC Consultant
Engineers & Contractors

5A Marouiya St . Haram-Giza- Cairo, Egypt.
6th Floor. (Apartment No.: B)

TEL NO.: 00202- 7447036 / 7601614
TEL NO.: 002010-1501790

REF NC: 2W-07/2007

DATE : August 27, 2007

TIME : 11:00 AM

TO : Whom it may Concern

FAX NC : -

ATTN. : -

CC :

FROM : Eng. Tarek Fathey

TOTAL : 1 (Including this page)

RE: REF PROJECTS FOR 2 WIRES Co.

Dear Sir,

With ref. to the above-mentioned subject we would like to declare that 2 wires had been involved in some of our projects and have done a very professional, respective work in the expected period of time.

This has been achieved during the last 7 years in the following projects.

No.	Project Name
1	CIB Giza Branch
2	Sonesta Hotel-Cairo
3	مبنى الرقابة الإدارية (الأسكندرية)
4	مبنى وزارة الثقافة (الأوبرا)

This certificate was given to 2 wires upon their request with no legal obligation

Sincerely Yours

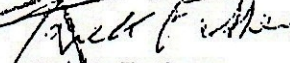
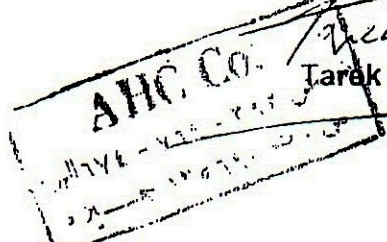
Tarek Fathey

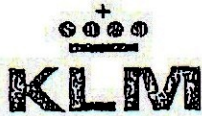

Royal Dutch Airlines

TO WHOM IT MAY CONCERN

September 1997

During the complete renovation of our office, Engineer Ossama Adib was responsible for all the works concerning electricity, air conditioning as well as the network for telephones and computers. The cooperation between Mr. Adib and ourselves was excellent.

Yours sincerely,

KLM Royal Dutch Airlines

J. W. Goudriaan
Marketing Manager Northern Africa

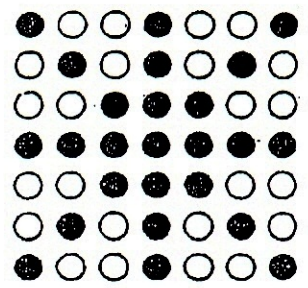

31 March 1993

This is to Certify that

Eng. Osama Adeeb Milad

participated in the restoration of the British Council office and
Library in Cairo during Ramadan 1993.

This Certificate is provided in recognition of the high standard
of his contribution and the special efforts he made in successfully
completing the work on time.



Representative of the British Council
in Egypt

مجموعة

شركة الفتيح للاستثمارات والمشروعات
شركة مساهمة مصرية

الرقم :

١٠٧٣

التاريخ :

٢٠١٢ / ٩ - ٢٢

قطاع المقاولات

أمر اسناد

السادة / شركة تو وايرز

تحية طيبة .. وبعد ..

بالإشارة الى أعمال التهوية

بعملية : اعمال انشاء المنطقة الصناعية بالكيلو ٢٤ طريق السويس بمسكن مبارك .

يرجى إتخاذ اللازم نحو البدء فى تنفيذ الأعمال طبقاً للفئات المعتمدة من استشارى المشروع والعبارة بما يتم تنفيذه على الطبيعة طبقاً للحصر المعتمد من استشارى المشروع على ان يتم تنفيذ الأعمال طبقاً للمواصفات الموصوفة بمعرفة الإستشارى والرسومات والعينات المعتمدة . و ذلك طبقاً لشروط التعاقد مع الجهة المالكة وطبقاً للشروط الآتية ..

- ١ . الإلتزام بالشروط والمواصفات الفنية الخاصة بالمشروع وبنود وكميات مقايمة اعمال المشروع .
- ٢ . يلتزم المقاول بتقديم وإعتماد الرسومات التنفيذية من الإستشارى قبل البدء فى تنفيذ الأعمال .
- ٣ . المقاول مسئول عن سلامة عماله داخل العملية .
- ٤ . الأسعار تشمل جميع الإستقطاعات التى تقع على الشركة طبقاً للنسب السالده .
- ٥ . الأسعار تشمل الضرائب العامة على المبيعات .

٦ . مدة تنفيذ المهمة : يتم اهاء الأعمال بالمصانع طبقاً لما يلي

- مصنع المهمات : يتم اهاء الأعمال بتاريخ ٢٠٠٩/٦/١٥ .
- مصنع البطاطين : يتم اهاء الأعمال بتاريخ ٢٠٠٩/٦/٢٠ .
- مصنع الأخشاب : يتم اهاء الأعمال بتاريخ ٢٠٠٩/٦/٢٥ .

٧ . يخضع هذا العقد لأحكام القانون رقم ٨٩ لسنة ١٩٩٨ فيما لم يرد به نص فى العقد .

٨ . يتم صرف مستحقات الشركة عن الأعمال بمستخلصات طبقاً لتقديم الأعمال خلال اسبوع من تاريخ اعتماد

مستخلص المقاول من استشارى المشروع .

٩ . يتم تعليه نسبة ٥ % كضمان أعمال من المستخلصات الجارية ويتم رده بعد التسليم الإبتدائى للأعمال .

١٠ . يتم تعليه نسبة ٥ % كضمان ثمانى من المستخلصات الجارية ويتم رده فور انتهاء مدة الضمان وتسليم المشروع ثانياً

ونرجو سرعة البدء فى التنفيذ فوراً .

رئيس قطاع المقاولات

عسكر متا

مهندس /

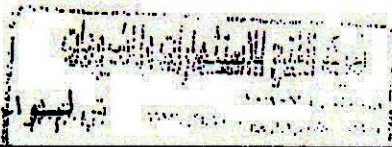

تليفون، ٢٢٩٠٢٨٨٦ - ٢٢٩٠٢٨١٤

قطاع التوريدات، ٢٢٩٠٢٥٩٩

قطاع المقاولات، ٢٢٩٢٢٠٠٩

القطاع الطبى، ٢٢٩٢٤٩٢٤

فاكس

العنوان ١١ ميدان السيدة زينب - القاهرة - برج الشرطة

ص.ب ٢١٠١ الدواوين - الرقم البريدى ١١٤٦١

افتتاح كاسل ديسكوتيك بهلنان شبرد



ناصر نصيف

صرح السيد/ناصر نصيف مدير فندق هلنان شبرد بأن ادارة هلنان العالمية فى اطار خطة تطوير شاملة للفندق قامت باعداد احداث ديسكوتيك فى مصر «كاسل» ليناكس المستويات العالمية وهو فى شكل قلعة رومانية جميلة وديكور يعيد الاصاله والتاريخ مع الاضاءه الخافتة الحاله تناسب اجواء القلعة الاسطورية وزودت القلعة باحدث اجهزة الصوت والضوء والصورة مع احداث الاغاني والموسيقى العالمية يقدمها دى جى القرن العشرين وجهزت القلعة باحدث اجهزة التكيف المركزى الالكترونى والشيف مختار الشهير اعد لكم احداث واتشى الاطباق التى تناسب ذلك الحداث.

وادارة جديدة وفكر جديد فى انتظارك



TWO WIRES

El Ganainy St., off Talaat Harb
Tel:5797380 Fax:5754960

الشركة المنفذة

لأعمال التجديدات والديكورات

بـ «كاسل ديسكوتيك»

فندق هلنان شبرد

جاردين سيتى - القاهرة

ت: ٣٥٥٣٨٠٠



THE
Scandinavian
HOSPITALITY

HELWAN
INTERNATIONAL
HOTELS

فندق هلنان شبرد - القاهرة
Helnan Shepherd Hotel
Cairo

القاهرة تشهد الليله افتتاح

كاسل ديسكوتيك

أحدث وأرقى ديسكوتيك فى مصر

تمتع بالرقص على أحدث موسيقى وإستعراضات عالم الديسكو

حفلات ماتينيه وسواريه وكاريوكى

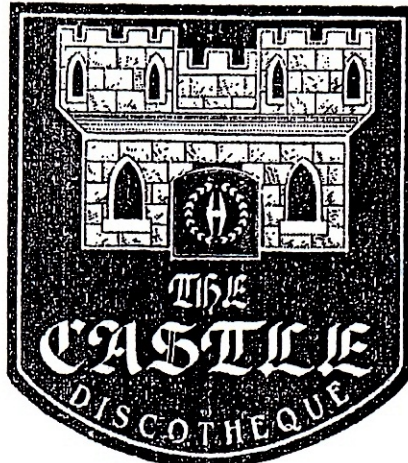

للحجز والإستعلام

فندق هلنان شبرد - جاردين سيتى - القاهرة - ت: ٣٥٥٣٨٠٠

THE
Scandinavian
HOSPITALITY

TO WHOM IT MAY CONCERN

We advise that Two Wires has successfully completed the Electromechanical Works For the following projects:

- Shephard-Hotel
- Villa Elgohara-Agouza.
- Four Season- Short Shop.
- Moghtar Villa- Mohamed Essin

The Works have been completed according to the Specifications and to the Satisfaction of the Consultant and the Client.

Signature.



Handwritten signature in Arabic script, likely reading 'محمد السيد' (Mohamed Essin).

Integrated general contracting
Dr. E h o b E z z a
شركة المقاولات العامة المتخصصة

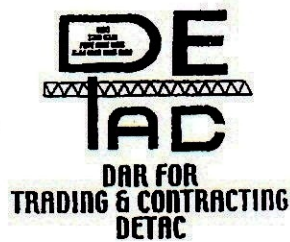

TO WHOM IT MAY CONCERN

We advise that Tow Wires company has successfully completed the air conditioning works for the following projects:

- Abu Ghazeleh Office Building (Will hand over 1/9/2007)
SMART VILLAGE-EGYPT
Over 3,000,000 E.P (three million Egyptian pound)
- Honda Dealership facility (IN GOING TO HAND OVER)
NEW CAIRO CITY
About 800,000 E.P (eight hundred pound)
- foreign production factory (IN GOING)
6th Zone- 6th of October.
19,000,000 E.P (nineteen million Egyptian pound)

Tow wires always finish the work according to the specifications and to the satisfaction of the consultant and the client.

Signature

DETAC

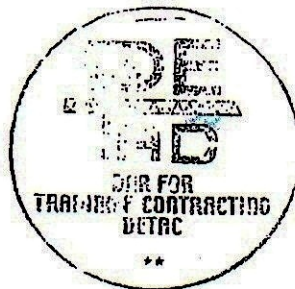

Certificate

To whom it may concern,

HSBC Bank Egypt certifies that Two Wires Company
(Eng. Ossama Adeeb) was commissioned for the
electromechanical works for the following projects as a sub
contractor of the general Contractor Conserv:

HSBC Bank Egypt – New Maadi Branch El Nasr St.
HSBC Bank Egypt – Sphinx Branch
HSBC Bank Egypt – Alexandria Branch (Ground Floor) and 2nd and 3rd
HSBC Bank Egypt – Back office 2nd and 3rd floors.
HSBC Bank Egypt – Head Office 9th Floor Aboul Feda Building
HSBC Bank Egypt – City Stars Branch.
HSBC Bank Egypt – Nasr City Branch
HSBC Bank Egypt – Obbour Branch
HSBC Bank Egypt – Mohandessien Branch.

All works have been done in accordance to HSBC
Standards and to our satisfaction.

HSBC Bank Egypt

HSBC Bank Egypt SAE

بنك إتش إس بي سي مصر ش.م.م.



P&G

شركة بروجكت وساميتك مصر بحاضر التكر والتقدم
اسم اديه
من شركة

على المهر والعظيم الذي هو السور والاسم
فهي التكر والاداري لشركة بايزم السابح سيني

مدرسة الفروع
جيهان قصر

فانبر رئيس الشركة
سنان مسيقن

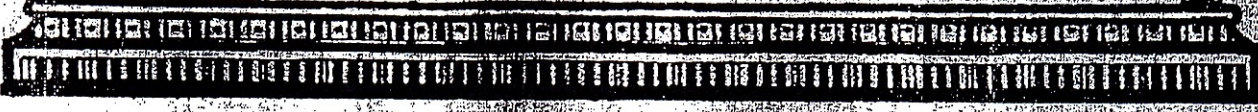
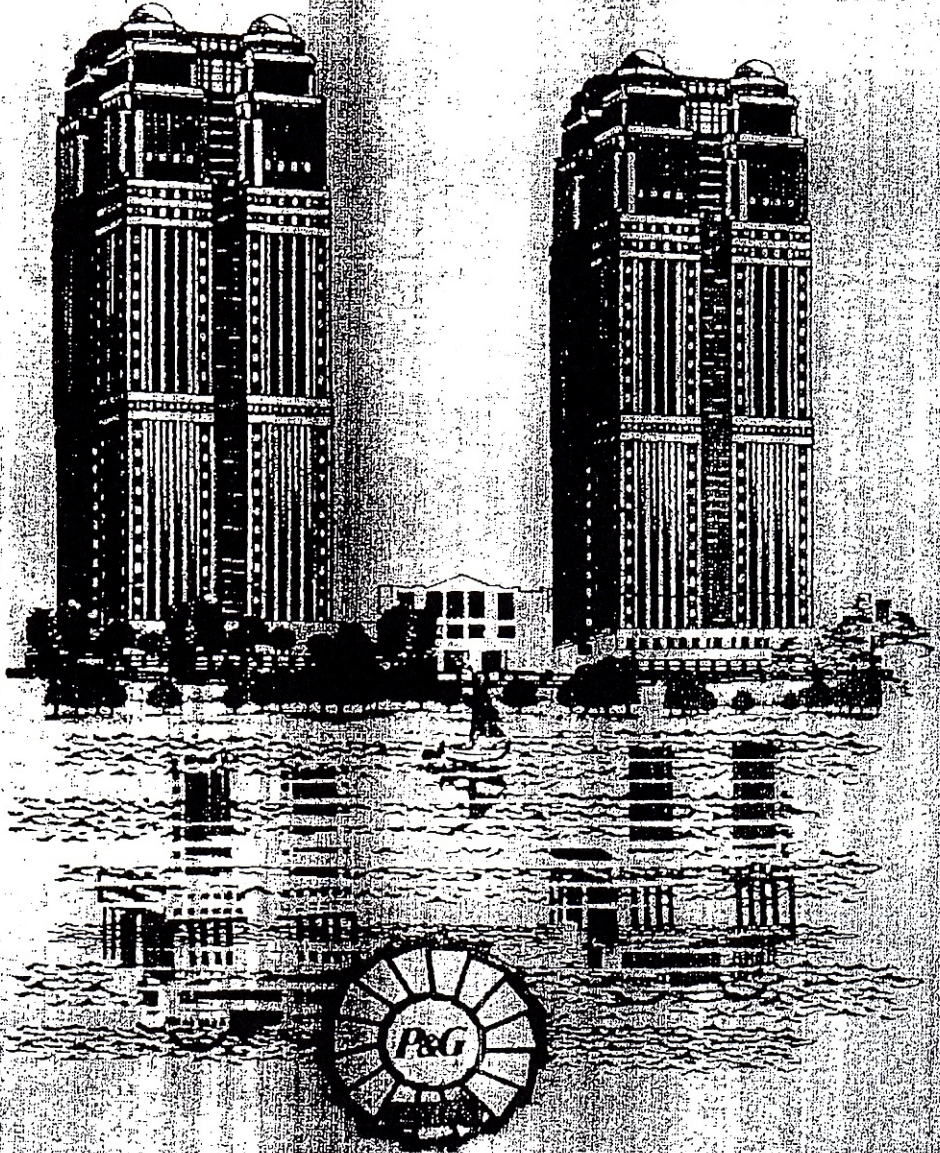

General Authority For Export & Import Control



الهيئة العامة للرقابة على
الصادرات و الواردات
(اس مستوردين)
بطاقة قيد في سجل المستوردين
رقم القيد ٥٨٢٢٢

صالحة من ٢٠٠٨/٠٣/٢٦ حتى ٢٠١٣/٠٣/٢٥

الاسم التجاري : اسامة اديب ميلاد

السمة التجارية : تو وايرز

نوع المنشأة : منشأة فردية

رأس المال : ٢٥٠٠٠٠ جنية

عنوان النشاط : تقسيم القانونين الحرفيين ٧٩ / ٢١٩ محل رقم ١ . العبور

المحافظة : القاهرة

تحريرا في ٢٠٠٨/٠٣/٢٧

رئيس مجلس الادارة
(محمد عبد الحميد البنا)

رقم السجل التجارى : ٣٦٣٠ وجهته : العبور - القاهرة
رقم التسجيل الضريبي : ٣٢٥-١٥٩-٠٣٣ مامورية : مدينة السلام
عدد المجموعات : ١١٠ رقم التليفون : ٠١٢٠٨٧٢١٢٢
المجموعات :
٥ - ٦ - ٧ - ٨ - ٩ - ١٠ - ١٣ - ١٥ - ١٦ - ١٧ - ٢٠ -
: اصل / نسخة ٢ / ١



**Federation
Of Egyptian
Contractors Registration**



الاتحاد المصري لمقاولي التشييد والبناء

فرع: القاهرة

(١٧٣٢)

رقم العضوية

٣٣٤٧٧

بطاقة عضوية من عام ٢٠١٣

00871

اسم المقاول / الشركة : اسامه اديب ميلاد - تو وايرز

تاريخ القيد بالاتحاد : ٢٠٠٨-٠٣-٠٨

نوع المنشأة : فردي

العنوان : تقسيم القانونيين - الحرفيين - محل رقم ١

المحافظة : القاهرة

مركز / قسم : السلام

تم تصنيف المقاول/الشركة طبقا للشعب والتخصصات والفئات الموضحة أمام كل منها بهذه البطاقة

٢٠١٤ / ٣ / ٣١

وينتهي العمل بهذه البطاقة في

٢٠١٣ / ٢٢٢٦

وسدد الاشتراك بالإيصال رقم

الفئة	التخصصات	الشعبة
XXX	أعمال المباني (متكامل).	الأولى
XXX	الأساسات.	الثانية
السادسه	الانشاءات المعدنية.	
XXX	الأعمال التكميلية.	
XXX	أعمال الطرق والكبارى والسكك الحديدية والمطارات.	
XXX	الأنفاق.	
السابعه	محطات وشبكات المياه والصرف الصحي وشبكات الغاز والوقود.	الثالثة
XXX	أعمال الأشغال العامة واعمال محطات القوى الحراريه والمانيه.	الرابعه
XXX	الأعمال البحريه والنهرية والتكريك.	الخامسه
XXX	استصلاح الاراضى.	
XXX	الابـار.	
الثالثه	الأعمال الكهروميكانيكية والالكترونية وشبكات الاتصال.	

رئيس مجلس الإدارة

مساعد الأمين العام

شئون العضوية

الموظف المختص

مهندس/حسن عبدالعزیز حسن

محاسب / هشام أحمد يسرى

تحريرا في ٢٠١٣-٠٢-١٣

ملحوظة : على جهات الإسناد التأكد من وجود علامة مائة للبطاقة

إلى السادة أصحاب الأعمال :

حررت هذه البطاقة طبقاً للقانون رقم (١٠٤) لسنة ١٩٩٢ بإنشاء الاتحاد المصري لمقاولي التشييد والبناء والقرار الوزاري رقم (١) لسنة ١٩٩٣ وتعديلاته باعتماد قواعد قيد وتصنيف وترتيب أعضاء الاتحاد المصري لمقاولي التشييد والبناء.

والقرار الوزاري رقم (٢٠٥) لسنة ١٩٩٣ بإصدار اللائحة التنفيذية للقانون رقم (١٠٤) لسنة ١٩٩٢.

يرجى الالتزام بما حدده القانون في هذا الشأن :

١- الحدود القصوى لقيمة المناقصات المسموح بدخوله فيها وفقاً لفئة تصنيفه بكل تخصص حسب الجدول المرفق، ويسمح بالتجاوز في حدود ١٥ ٪ من الحد الأعلى لكل فئة.

٢- يكون لصق تمغة الاتحاد إلزامياً على عقود المقاولات التي يوقعها عضو الاتحاد متى زادت على مائتي ألف جنيه بواقع نصف جنيه عن كل ألف جنيه بحد أقصى (٥٠٠٠ جنيه) خمسة آلاف جنيه للعقد الواحد أو سداد قيمتها للاتحاد بموجب إيصال معتمد منه، ويرفق بالعقد، ويرتبط التجديد السنوي لبطاقة العضوية بالالتزام بسداد قيمة التمغة المحددة وذلك طبقاً لنص المادة العاشرة من القانون رقم (١٠٤) لعام ١٩٩٢ والمادة الحادية عشرة من لائحته التنفيذية. الحدود العليا لقيمة المناقصات المسموح بالدخول فيها لكل فئة بكل تخصص (بالمليون جنيه)

التخصصات						
الأولى	الثانية	الثالثة	الرابعة	الخامسة	السادسة	السابعة
٢٠	٥٠	٣٠	٢٠	١٠	٤	٢
	٢٥	١٥	٨	٢	٠,٥	-
	٢٠	١٢	٨	٤	٠,٥	-
	٣	٢	١	٠,٥	-	-
٥٠	٥٠	٣٠	١٦	٨	٤	١
	٥٠	٣٠	١٦	-	-	-
	٥٠	٣٠	١٦	٨	٢	١
	٤٠	٢٥	١٦	٨	٤	١
	٤٠	٢٥	١٦	٨	٤	-
	٤٠	٢٥	١٦	٨	٤	١
	٢٥	١٥	٦	٢	٠,٥	-
	٢٥	١٥	٧	٣	١	-

يقوم الاتحاد بإصدار شهادة بيانات أصلية مؤقتة من واقع هذه البطاقة لإرفاقها بأوراق التقدم للمعطاءات، على أن يتم الاطلاع على أصل البطاقة عند التعاقد.

Accredited Papers

<p>(١) عنوان المحل الرئيسى (ب) عنوان المركز العام للشركة او الجمعية التعاونية (ج) رقم قيد المحل الرئيسى او المركز العام (فى حالة قيد الفرع)</p>	<p>(١) تاريخ الإيداع (ب) تاريخ القيد فى السجل التجارى (٢) رقم ايداع طلب التجديد (ب) تاريخ ايداع طلب التجديد (ج) تاريخ التجديد</p>	<p>(١) اسم التاجر ولقبه وتاريخ ومحل ميلاده وجنسيته (ب) اسماء والقبائل الشركاء المسنولين بالتضامن فى شركات التضامن او التوصية البسيطة و تاريخ ومحل الميلاد لكل منهم وجنسيته (ج) اسماء والقبائل الشركاء او غيرهم المنوط بهم ادارة الشركة ومن لهم حق التوقيع باسمها وصفة كل منهم وتاريخ ومحل ميلاده وجنسيته ومدى سلطتهم فى الادارة والتوقيع (د) اسماء والقبائل اعضاء مجلس الادارة فى شركات المساهمة او الجمعية التعاونية ووكلائها المديرين وصفة كل منهم وتاريخ ومحل ميلاده وجنسيته ومدى سلطتهم فى الادارة والتوقيع (هـ) اسم و لقب مدير الفرع الرئيسى او الوكالة العامة فى جمهورية مصر العربية وتاريخ ومحل ميلاده وجنسيته (اذا كان المركز العام فى للشركة الخارج)</p>	<p>(١) نوع التجارة او (ب) الغرض من تأسيس الشركة او الجمعية التعاونية</p>	<p>(١) رقم الإيداع (ب) تاريخ الإيداع (ج) رقم القيد فى السجل التجارى (٢) رقم ايداع طلب التجديد (ب) تاريخ ايداع طلب التجديد (ج) تاريخ التجديد</p>	<p>(١) رقم الإيداع (ب) تاريخ الإيداع (ج) رقم القيد فى السجل التجارى (٢) رقم ايداع طلب التجديد (ب) تاريخ ايداع طلب التجديد (ج) تاريخ التجديد</p>
<p>(١) تم اضافته فرع بالعنوان [٨] ٥٥ ش المنتزه - النزهة اودع برقم ١٥٥٢٧ فى ٢٠١٠/١٠/١٢ وقيد بدالم رقم تابع ٣٨٤٠٦٦ القاهرة مصر الجديدة القاهرة تم اضافته فرع بالعنوان ٦ ش مختار حسين من ش الحجاز النزهة اودع برقم ١٥٥٢٦ فى ٢٠١٠/١٠/١٢ وقيد برقم تابع ٣٨٤٠٦٦ النزهة القاهرة</p>	<p>(١) تقسيم القانونيين الحريين قى ٢١٩ / ٧٩ محل رقم ١ القاهرة</p>	<p>(١) ٢٠٠٢/٠٥/١٩ - ١ ٢٠٠٢/٠٥/١٩ - ٢</p>	<p>(١) ورشه اعمال كهروميكانيكيه (١) ٢١ ٢١ اضافته نشاط المقاولات العموميه (١) ٢١ ٢١ تم اضافته نشاط الاستيراد والتوكيلات التجاربه</p>	<p>(١) اسماه اديب ميلاد نيمترى ١٩٦١/١٢/٢٦ مصر القاهرة كامل الالهيه</p>	<p>(١) ٤٨٠ - أ ب - ٢٠٠٢/٠٥/٢٥ ج - ٣٦٣٠ - (٢) ٦٥٧ - أ ب - ٢٠٠٧/٠٦/٠٣ سارى حتى ٢٠١٢/٠٥/٢٤ (٢) ٦٨٣ - أ ب - ٢٠١٢/٠٥/١٦ القيد سارى حتى ٢٠١٧/٥/٢٤</p>

مستخرج من السجل التجارى رقم: ٣٦٣٠
اي كشط او شطب او تعديل باليد يلغى هذه الوثيقة

<p>(١) الاحكام و القرارات الصادرة بتوقيع المحز على التاجر او بتعيين القامة و الوكلاء عن العائين بمزلةم او برفع المحز (ب) الاحكام و الاوامر المتعلقة بالانلاس (ج) احكام اعادة الاعتبار (د) الاحكام الصادرة بالطلاق او الفترقة الجسمانية او المالية و القرارات الصادرة باعطاء الاذن للتاجر بالتاجر او الغائه او الحد منه (هـ) احكام فصل الشركاء او عزل المديرين واحكام حل الشركات او بطلانها وتعيين المصفين او عزلهم (و) البيانات المتعلقة ببيع المحل التجارى او رهنه طبقا للقانون رقم ١١ لسنة ١٩٤٠</p>	<p>(١) النظام المالى الذى حصل الزواج على مقتضاه (ب) الاهلية التجارية (ج) كل عقد يقضى بحل الشركة او وضعها تحت التصفية</p>	<p>رقم التسجيل: (١) العلامات التجارية (ب) براءات الاختراع (ج) الرسوم و النماذج الصناعية</p>	<p>(١) المحال التي كانت لتاجر سابقا (ب) المحال التي تكون له: ١- فى دافرة نفس المكتب ٢- فى دافرة مكاتب اخرى</p>	<p>(١) مقدار رأس المال المستخر في المحل الرئيسى للتاجر والفروع والوكالات التابعة له (ب) مقدار رأس مال الشركة او الجمعية التعاونية ١- مبالغ الموداة منه ٢- مبالغ تمعد الشركاء بأدائها ٣- مقدار حصصة الشركاء الموصين ٤- قيمة الحصص العينية ان وجدت (ج) رصيد الفروع المدن للمركز العام للشركة</p>	<p>(١) الوكلاء المفوضون (ب) مدير الفروع او الوكالة واسم و لقب كل منهم تاريخ و محل مولاده وجنسيته</p>
(١٤)	(١٣)	(١٢)	(١١)	(١٠)	(٩)
<p>مامش</p> <p>٢٠٠٣/٠٣/١٩ ٣٠٥ ٢٠٠٥/٠٣/١٩ ٣٠٥ ٢٠٠٧/٠٢/١٤ ٢٣٣ ٢٠٠٧/٠٦/٠٣ ٦٥٧ ٢٠٠٧/٠٧/٠٩ ٧٧٩ ٢٠٠٨/٠٣/١١ ٢٧٥ ٢٠٠٩/٠٧/١٥ ٧٢٦ ٢٠١٠/١٠/١١ ١١٤٨ ٢٠١٢/٠٥/١٦ ٦٨٣</p>				<p>(١) [٣٦] تم افتتاح محل رئيسى اخر بالعنوان ١٧٥ النزهه بالتزه مصر الجديده بتنشاط مركز ادارى يراس مال قدره ٥٠٠ ج لاغير اودع برقم ١٨٧٢ بتاريخ ٢٠٠٧/٠٢/٢٠ وقيد برقم ٣٨٤٠٦٦ القايرة</p>	<p>(١) مقدار رأس المال ٢٠٠٠٠ جنيه مصرى (١) [١١] مقدار رأس المال ٥٠٠٠٠ جنيه مصرى (١) [٥١] مقدار رأس المال ٢٥٠٠٠٠ جنيه مصرى (١) [٧١] مقدار رأس المال ٤٠٠٠٠٠٠ جنيه مصرى</p>

فى:

فى: ٢٠١٣/١/١٣

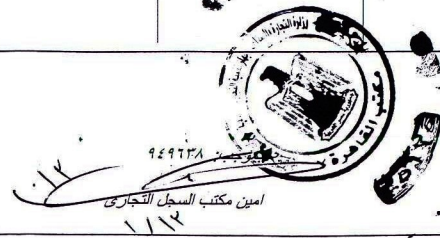

اسم طالب المستخرج: ماجد امين وليم

وقد سددت الرسوم و قدرها: ٤,٠٠٠

تحريرا فى:

١٧٥
٢٠١٣/١/١٣

جمهورية مصر العربية



وزارة المالية
مصلحة الضرائب

البطاقة الضريبية

رقم البطاقة الضريبية
٦٢٤٦

٣٢٥-١٥٩-٠٣٣

رقم التسجيل الضريبي

325-159-033

مدينة السلام

المأمورية التابع لها :

١٦٦

كود المأمورية :

اسم الممول : تو وايرز اسامه اديب ميلاد

اسم الممول :

ديمتري

عنوان الممول : تقسيم القانونيين الحرفيين

عنوان الممول :

رقم الملف : ٥-٠١٢٦١-٣٢٠-٠٠٠-٢٧

رقم الملف :

النشاط : أعمال كتر سبلايكتي و مقار
٠٠٠١٣

إرشادات للممول

- ١- تصدر هذه البطاقة بناء على طلب يقدم إلى المأمورية المختصة
- ٢- يحظر على الجهات المبينه في المادة ١٢٩ من القانون ١٥٧ لسنة ١٩٨١ التعامل مع الممول إلا إذا كان حاصلًا على هذه البطاقة و ثابت بها تاريخ تقديم الإقرار الضريبي عن آخر سنة
- ٣- يتعين تقديم هذه البطاقة للمأمورية لإثبات تاريخ تقديم الإقرار الضريبي أو إقرار الثروة أو عند حدوث تغيير في البيانات لإثبات هذا التغيير
- ٤- لا يجوز للممول أن يحصل إلا على بطاقة ضريبية واحدة مهما تعددت أنشطة التجارية أو المهنية أو الفروع ويكون ذلك من مأمورية المركز الرئيسي
- ٥- تسلم هذه البطاقة عند :
أ- إنتهاء مدة سريانها
ب- عند توقفه كليًا عن مباشرة النشاط

ملحق البطاقة الضريبية

رقم التسجيل الضريبي

325-159-033



اسم الممول : تو وايرز اسامه اديب ميلاد

أخت سارة رقم ١٨٦١٠٩ ديمتري

٤١٢٢ ٣ ٢٠٨٠٠٤٣ أخت راس ٢٠٦٢/١٢

أخت سارة رقم ١٩٥٤٩٢ نقل كاسم

٤١٢٤٢٧ مارتا ٢١١٦٩٥ أخت راس ٢٠٧/٢/٢٦

بناد ١٣٠٤٦ مارتا أخت راس ٢٠٧/٢/٢٦

سليم وطفة سارة أخت راس ٢٠٧/٢/٢٦

٩ عز ٢٦٠٤٦ الله أبو لينا أخت راس ٢٠٧/١٠/١٢

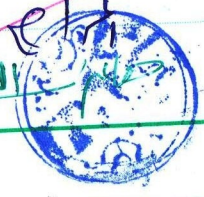

الاسم
٢٩/٤/٢٦

الاسم التجاري : تو وايرز اسامه اديب ميلاد

عنوان النشاط : مطبوعة ٧٩ قبة لمارتريه الحرم

رقم تحقيق الشخصية : ٢١٩ ١٩٥٢١٤ النشاط

الجنسية : مصر

السجل التجاري : /

سجل الشركات : /

المركز الرئيسي : /

الفروع - ١ : /

- ٢ : /

- ٣ : /

تاريخ بداية النشاط : ٢٠١/٨/١٥

الكيان القانوني : فرد

رقم التأمينات الاجتماعية : /

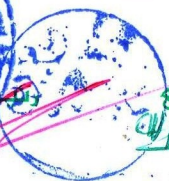
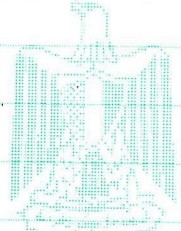

المراجع
مخزن

المأمور
٢٠٩/٤/٢٦

بناء على طلب المحول رقم ١١٢٩ / ١٤٦١ / ٢٥
تم تغيير رقم لوائح السيارة ١٨٦١٩ إلى ١١٩ بنفس

السيارة الكونور بتاريخ ١٤٧٠ / ١٨ / ٥٠

تم تغيير رقم لوائح السيارة ٥٨٠٠٥٨ إلى ٥٨٠٥٨ بنفس

نفس السيارة الكونور بتاريخ ١٤٧٠ / ١٢ / ٥٠
سور
فاده
٥٠١٢١١٧

بناء على طلب برقم ١٩١ تاريخ ١٤٦١ / ١٢ / ٥٠
أضمانه كاط سياره ايمو رقمه ١٨٦١٩

٨٥١ تاريخ رقمه ١٦٥٤٦ موديل ١٩٨٥

٩٤٨٦٠ تاريخ حرف اللوائح ١٤٦٢ / ١٢ / ٥٠

١٠١٩٦١٨ تاريخ رقمه ١٤٦٢ / ١٢ / ٥٠

٢٧٤٨٦



بناء على طلب المحول برقم وارو وتاريخ ١٤٥٦ / ١٨ / ٥٠

وبناء على كاط سياره ايمو رقمه ١٨٦١٩ بنفس

برقمه ١٤٥٠ تاريخ رقمه ١٤٦١ / ١٢ / ٥٠

مراجع
٩١٨١٤



بناء على الطلب المحول برقم ٥٠٥٦ تاريخ ١٤٦٢ / ١٢ / ٥٠

مع اضافة الشارة طرف م ٢٦٧ رقمه ١٤٦٢ / ١٢ / ٥٠

مورد رقمه ١٤٦٢ / ١١ / ٥٠
مورد رقمه ١٤٦٢ / ١١ / ٥٠

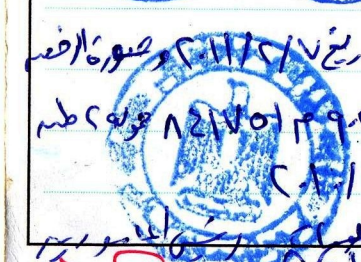

إقرار ضريبي / إقرار ثروة		
التوقيع	بيانات الإقرار	ملاحظات
	عنوان: ممرات بلدية الجبل رقم: ٢٧٦	
	رقم الإقرار: ٢٠٠٨ ١٧ / ٢ / ٢٠١٧	
	عنوان: بلدية السلام رقم: ٢٧٦	
	رقم الإقرار: ٢٠١٧	
<div style="border: 2px solid blue; padding: 5px; width: fit-content;"> <p>مأمورية ضرائب مدينة السلام إقرار ضريبي - عام ٢٠١٧ رقم الوارد: ٢٠١٧</p> </div>		٢٩
بيانات عن أية إعفاءات ضريبية: ٢٠١٧		
تاريخ الإصدار: تاريخ الإنتهاء:		

بناء على طلبه وحيل لجميله في إظهاره لإقراره من ماسور
 صبراني لنزله جم ١٤٤٢ تاريخ ٢٠١٧/٥/١٠
 تم إيفاء مركز إدارة جم (٩) لنشاط أعمال
 كهر صيكتيك ومضارلات واستيراد وتصدير
 بالعضوية ٦-٥ ومضار صين من سنة إيجاز
 النزله ريدايه نشاطه ٩/١٤/٢٠١٧ - ٩
 إقراره رقم ٥/١٦١/٥/٢٠١٧ بنفسه بكماله
 القانوني فردى

ممرات بلدية الجبل

ماسور المرامح
 بشل رقم ٥/١٦١/٥/٢٠١٧



(نموذج ٣ ض.ع.م)

جمهورية مصر العربية

وزارة المالية

مصلحة الضرائب على المبيعات

مأمورية: حريته السلام



أعمال كروبيداتيك
فردى

الضريبة العامة على المبيعات

شهادة تسجيل

هذه شهادة منابان: أسامة أويب صلاوي عمرو (توآيز للأعمال بلديك)
العنوان: كصيم القانو نيين الحرقين
قد تم تسجيله وفقا لنصوص قانون الضريبة العامة على المبيعات.

تحت رقم: ١٣٣ - ١٥٩ - ٢٩٥

وذلك اعتبارا من ٢٠٠٤/٧/٢٨



د/ رئيس المصلحة

محمد مصطفى